

MOSA

GE 15 YSX

0313

849109003 - GB

USE AND MAINTENANCE MANUAL

I
GB
F

DESCRIPTION OF THE MACHINE

GE 15 YSX

M
0
REV.0-09/12

The generating set is a unit which transforms the mechanical energy, generated by endothermic engine, into electric energy, through an alternator.

The unit is composed of a structured base which includes a tank, an engine/alternator unit fixed on the base by elastic dampers, a roll-bar, with hook for an easy and sure lifting, a chest hinged to the roll-bar for a quick access to the engine and to the air filter.

The set is completed by a frontal panel where the sockets, the protections and the measuring instruments are mounted, all this protected by a same sized cover.

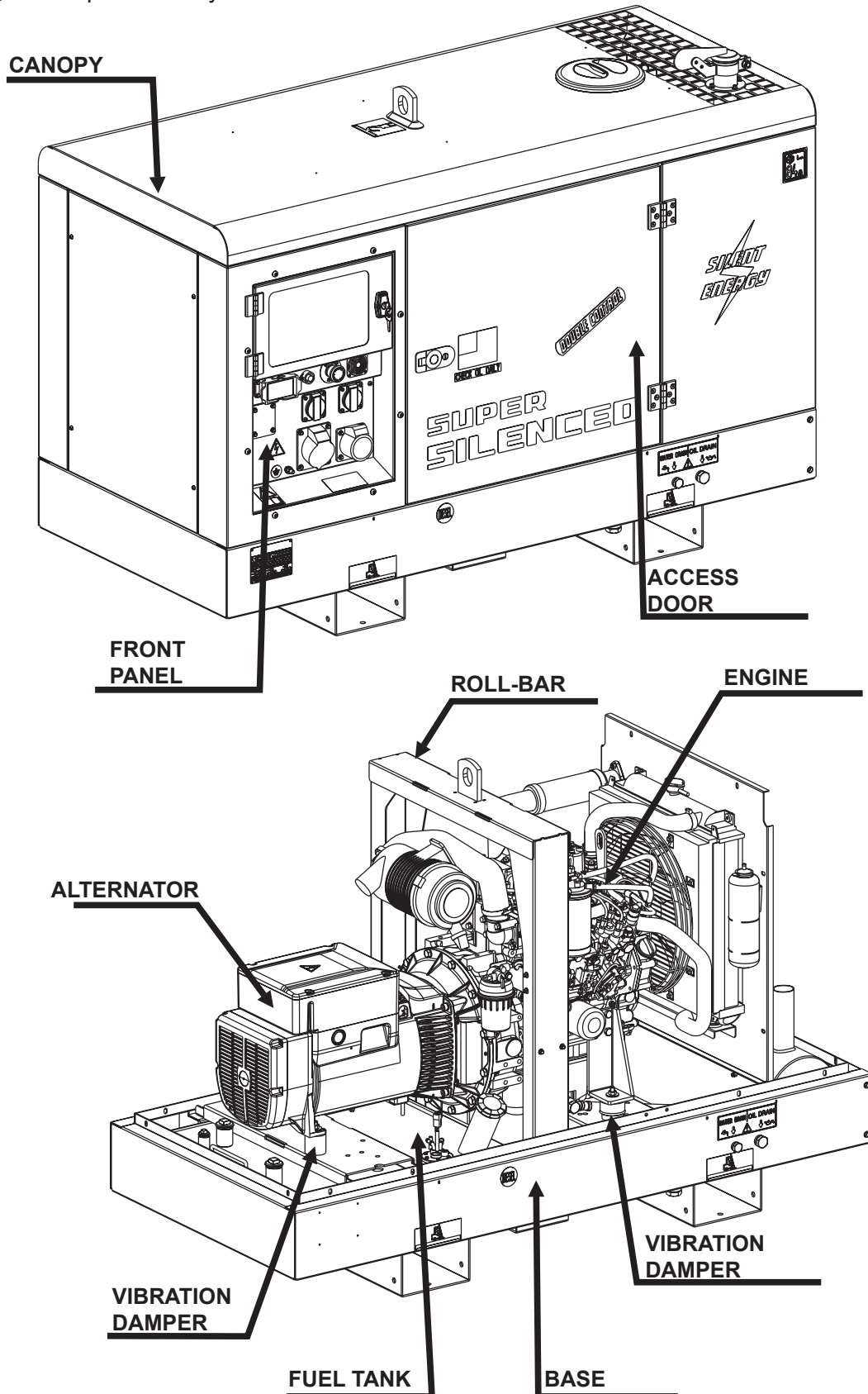



UNI EN ISO 9001 : 2008

ISO 9001:2008 - Cert. 0192

MOSA has certified its quality system according to UNI EN ISO 9001:2008 to ensure a constant, high quality of its products. This certification covers the design, production and servicing of engine driven welders and generating sets.

The certifying institute, ICIM, which is a member of the International Certification Network IQNet, awarded the official approval to MOSA after an examination of its operations at the head office and plant in Cusago (MI), Italy.

This certification is not a point of arrival but a pledge on the part of the entire company to maintain a level of quality of both its products and services which will continue to satisfy the needs of its clients, as well as to improve the transparency and the communications regarding all the company's activities in accordance with the official procedures and in harmony with the MOSA Manual of Quality.

The advantages for MOSA clients are:

- Constant quality of products and services at the high level which the client expects;
- Continuous efforts to improve the products and their performance at competitive conditions;
- Competent support in the solution of problems;
- Information and training in the correct application and use of the products to assure the security of the operator and protect the environment;
- Regular inspections by ICIM to confirm that the requirements of the company's quality system and ISO 9001 are being respected.

All these advantages are guaranteed by the CERTIFICATE OF QUALITY SYSTEM No.0192 issued by ICIM S.p.A. - Milano (Italy) - www.icim.it

| | |
|-------------|-----------------------------------|
| M 0 | DESCRIPTION OF THE MACHINE |
| M 01 | QUALITY SYSTEM |
| M 1.01 | COPYRIGHT |
| M 1.1 | NOTES |
| M 1.4 | CE MARK |
| M 1.4.1 | DECLARATION OF CONFORMITY |
| M 1.5 ... | TECHNICAL DATA |
| M 2-2.1... | SYMBOLS AND SAFETY PRECAUTIONS |
| M 2.5 ... | ADVICE |
| M 2.6 | INSTRUCTIONS FOR THE INSTALLATION |
| M 2.7 ... | INSTALLATION AND DIMENSIONS |
| M 3 | UNPACKING |
| M 4.2 | TRANSPORT AND HANDLING |
| M 20 | SET-UP FOR OPERATION |
| M 21 | START AND STOP |
| M 31 | CONTROLS |
| M 32 | CONTROLS |
| M 39.12... | EP6 ENGINE PROTECTION |
| M 37 -..... | USING THE GENERATOR |
| M 39.10 | INSULATION MONITORING PROTECTION |
| M 29.1... | PREDISPOSITION AUTOMATIC LOADING |
| M 29.2 | 3-WAY VALVE FUEL SYSTEM KIT |
| M 38.6 | TCM 35 REMOTE CONTROL |
| M 43 -..... | MAINTENANCE OF THE MACHINE |
| M 40.2 | TROUBLE-SHOOTING |
| M 45 | STORAGE |
| M 46 | CUST OFF |
| M 60 | ELECTRICAL SYSTEM LEGEND |
| M 61-..... | ELECTRICAL SYSTEM |



ATTENTION

This use and maintenance manual is an important part of the machines in question.

The assistance and maintenance personnel must keep said manual at disposal, as well as that for the engine and alternator (if the machine is synchronous) and all other documentation about the machine.

We advise you to pay attention to the pages concerning the security (see page M1.1).



© All rights are reserved to said Company.

It is a property logo of MOSA division of B.C.S. S.p.A. All other possible logos contained in the documentation are registered by the respective owners.

🚫 The reproduction and total or partial use, in any form and/or with any means, of the documentation is allowed to nobody without a written permission by MOSA division of B.C.S. S.p.A.

To this aim is reminded the protection of the author's right and the rights connected to the creation and design for communication, as provided by the laws in force in the matter.

In no case MOSA division of B.C.S. S.p.A. will be held responsible for any damage, direct or indirect, in relation with the use of the given information.

MOSA division of B.C.S. S.p.A. does not take any responsibility about the shown information on firms or individuals, but keeps the right to refuse services or information publication which it judges discutible, unright or illegal.

INFORMATION

Dear Customer,
We wish to thank you for having bought a high quality set.

Our sections for Technical Service and Spare Parts will work at best to help you if it were necessary.

To this purpose we advise you, for all control and overhaul operations, to turn to the nearest authorized Service Centre, where you will obtain a prompt and specialized intervention.

☞ In case you do not profit on these Services and some parts are replaced, please ask and be sure that are used exclusively original parts; this to guarantee that the performances and the initial safety prescribed by the norms in force are re-established.

☞ *The use of **non original spare parts will cancel immediately any guarantee and Technical Service obligation.***

NOTES ABOUT THE MANUAL

Before actioning the machine please read this manual attentively. Follow the instructions contained in it, in this way you will avoid inconveniences due to negligence, mistakes or incorrect maintenance. The manual is for qualified personnel, who knows the rules: about safety and health, installation and use of sets movable as well as fixed.

You must remember that, in case you have difficulties for use or installation or others, our Technical Service is always at your disposal for explanations or interventions.

The manual for Use Maintenance and Spare Parts is an integrant part of the product. It must be kept with care during all the life of the product.

In case the machine and/or the set should be yielded to another user, this manual must also given to him.

Do not damage it, do not take parts away, do not tear pages and keep it in places protected from dampness and heat.

You must take into account that some figures contained in it want only to identify the described parts and therefore might not correspond to the machine in your possession.

INFORMATION OF GENERAL TYPE

In the envelope given together with the machine and/or set you will find: the manual for Use Maintenance and Spare Parts, the manual for use of the engine and the tools (if included in the equipment), the guarantee (in the countries where it is prescribed by law).

Our products have been designed for the use of generation for welding, electric and hydraulic system; ANY OTHER DIFFERENT USE NOT INCLUDED IN THE ONE INDICATED, relieves the manufacturer from the risks which could happen or, anyway, from that which was agreed when selling the machine. The manufacturer excludes any responsibility for damages to the machine, to the things or to persons in this case.

Our products are made in conformity with the safety norms in force, for which it is advisable to use all these devices or information so that the use does not bring damage to persons or things.

While working it is advisable to keep to the personal safety norms in force in the countries to which the product is destined (clothing, work tools, etc.).

Do not modify for any motive parts of the machine (fastenings, holes, electric or mechanical devices, others..) if not duly authorized in writing: the responsibility coming from any potential intervention will fall on the executioner as in fact he becomes maker of the machine.

☞ **Notice:** *this manual does not engage the manufacturer, who keeps the faculty, apart the essential characteristics of the model here described and illustrated, to bring betterments and modifications to parts and accessories, without putting this manual uptodate immediately.*



Any of our product is labelled with CE marking attesting its conformity to applicable directives and also the fulfillment of safety requirements of the product itself; the list of these directives is part of the declaration of conformity included in any machine standard equipment. Here below the adopted symbol:



CE marking is clearly readable and unerasable and it can be either part of the data-plate.

| | | | |
|----------------|--------------------|--|---------------------|
| | | Made in UE-ITALY TYPE SERIAL N° | |
| | X | | |
| | I ₂ (A) | | |
| U ₀ | U ₂ (V) | | |
| | I ₂ (A) | | |
| | U ₀ | U ₂ (V) | |
| Hz | kVA | | |
| P.F. | V (V) | | |
| | I (A) | | |
| | n | RPM | n ₁ RPM |
| | n ₀ | RPM | P _{max} KW |
| | | IP | I. CL. |

| | | | |
|--------------|-------------|--|------|
| | | Made in UE-ITALY TYPE Generating Set ISO 8528 SERIAL N° | |
| KVA | | | |
| V | | | |
| I | | | |
| Hz | P.F. | LTP POWER IN ACCORDANCE WITH ISO 8528 | |
| RPM | I. CL. | | IP |
| ALTIT. 100 m | TEMP. 25 °C | | MASS |

Furthermore, on each model it is shown the noise level value; the symbol used is the following:

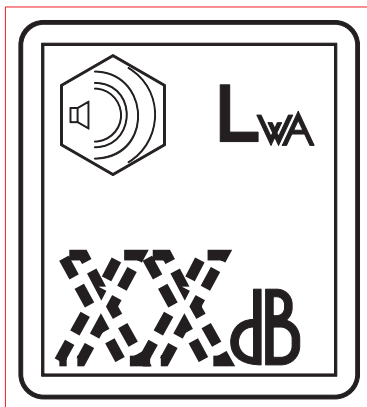

The indication is shown in a clear, readable and indeleble way on a sticker.

BCS S.p.A.

Sede legale:
Via Marradi 1
20123 Milano - Italia

Stabilimento di Cusago, 20090 (MI) - Italia

V.le Europa 59
Tel.: +39 02 903521
Fax: +39 02 90390466



ISO 9001:2000 - Cert. 0192

DICHIARAZIONE DI CONFORMITA'



Déclaration de Conformité – Declaration of Conformity – Konformitätserklärung
Conformiteitsverklaring – Declaración de Conformidad

BCS S.p.A. dichiara sotto la propria responsabilità che la macchina:
BCS S.p.A. déclare, sous sa propre responsabilité, que la machine:
BCS S.p.A. declares, under its own responsibility, that the machine:
BCS S.p.A. erklärt, daß die Aggregate:
BCS S.p.A. verklaard, onder haar eigen verantwoordelijkheid, dat de machine:
BCS S.p.A. declara bajo su responsabilidad que la máquina:

GRUPPO ELETTROGENO DI SALDATURA / WELDING GENERATOR

GRUPPO ELETTROGENO / POWER GENERATOR

Marchio / Brand : MOSA

Modello / Model : _____

Matricola / Serial number : _____

è conforme con quanto previsto dalle Direttive Comunitarie e relative modifiche:
est en conformité avec ce qui est prévu par les Directives Communautaires et relatives modifications:
conforms with the Community Directives and related modifications:
mit den Vorschriften der Gemeinschaft und deren Ergänzungen übereinstimmt:
in overeenkomst is met de inhoud van gemeenschapsrichtlijnen gerelateerde modificaties:
comple con los requisitos de la Directiva Comunitaria y sus anexos:

2006/42/CE - 2006/95/CE - 2004/108/CE

Nome e indirizzo della persona autorizzata a costituire il fascicolo tecnico :

Nom et adresse de la personne autorisée à composer le Dossier Technique :

Person authorized to compile the technical file and address :

Name und Adresse der zur Ausfüllung der technischen Akten ermächtigten Person :

Persoon bevoegd om het technische document , en bedrijf gegevens in te vullen

Nombre y dirección de la persona autorizada a componer el expediente técnico :

ing. Benso Marelli - Amministratore Delegato / CEO; V.le Europa 59, 20090 Cusago (MI) - Italy

Cusago,

Ing. Benso Marelli
Amministratore Delegato
CEO



Technical data

GE 15 YSX

GENERATOR

| | |
|----------------------------|-----------------------------------|
| Stand-by three-phase power | 15 kVA (12 kW) / 400 V / 21.6 A |
| PRP three-phase power | 14 kVA (11.2 kW) / 400 V / 20.2 A |
| PRP single-phase power | 6.5 kVA / 230 V / 28.3 A |
| Frequency | 50 Hz |
| Cos φ | 0.8 |

ALTERNATOR

| | |
|------------------|---|
| Type | self-excited, self-regulated, brushless |
| Insulation class | synchronous, three-phase |
| | H |

ENGINE

| | |
|-------------------------------|--------------------------|
| Make / Model | YANMAR 3TNV88 |
| Type / Cooling system | Diesel 4-Stroke / water |
| Cylinder / Displacement | 3 / 1642 cm ³ |
| *Stand by net power | 13.6 kW (18.5 HP) |
| **PRP net power | 12.3 kW (16.5 HP) |
| Speed | 1500 rpm |
| Fuel consumption (75% of PRP) | 2.6 l/h |
| Engine oil capacity | 6.7 l |
| Starter | Electric |

GENERAL SPECIFICATIONS

| | |
|---|---------------------------|
| Tank capacity | 55 l |
| Running time (75% of PRP) | 21 h |
| Protection | IP 44 |
| *Dimensions / max. on base Lxwxh | 1680x770x1190 |
| *Weight on base | 630 Kg |
| Measured acoustic power Lwa (pression LpA) | 85 dB(A) (60 dB(A) @ 7 m) |
| Garanteed acoustic power Lwa (pression LpA) | 86 dB(A) (61 dB(A) @ 7 m) |



* Dimensions and weight are inclusive of all parts.

OUTPUT

Declared power according to ISO 8528-1 (temperature 25°C, 30% relative humidity, altitude 100 m above sea level).

(*Stand-by) = maximum available power for use at variable loads for a yearly number of hours limited at 500 h. No overload is admitted.

(**Prime power PRP) = maximum available power for use at variable loads for a yearly illimited number of hours. The average power to be taken during a period of 24 h must not be over 80% of the PRP.

It's admitted overload of 10% each hour every 12 h.

In an approximative way one reduces: of 1% every 100 m altitude and of 2.5% for every 5°C above 25°C.

ACOUSTIC POWER LEVEL

ATTENTION: The concrete risk due to the machine depends on the conditions in which it is used. Therefore, it is up to the end-user and under his direct responsibility to make a correct evaluation of the same risk and to adopt specific precautions (for instance, adopting a I.P.D. -Individual Protection Device)

Acoustic Noise Level (LWA) - Measure Unit dB(A): it stands for acoustic noise released in a certain delay of time. This is not submitted to the distance of measurement.

Acoustic Pressure (Lp) - Measure Unit dB(A): it measures the pressure originated by sound waves emission. Its value changes in proportion to the distance of measurement.

The here below table shows examples of acoustic pressure (Lp) at different distances from a machine with Acoustic Noise Level (LWA) of 95 dB(A)

Lp a 1 meter = 95 dB(A) - 8 dB(A) = 87 dB(A)

Lp a 4 meters = 95 dB(A) - 20 dB(A) = 75 dB(A)

Lp a 7 meters = 95 dB(A) - 25 dB(A) = 70 dB(A)

Lp a 10 meters = 95 dB(A) - 28 dB(A) = 67 dB(A)

PLEASE NOTE: the symbol  when with acoustic noise values, indicates that the device respects noise emission limits according to 2000/14/CE directive.

SYMBOLS IN THIS MANUAL

- The symbols used in this manual are designed to call your attention to important aspects of the operation of the machine as well as potential hazards and dangers for persons and things.

IMPORTANT ADVICE

- Advice to the User about the safety:

☞ N.B.: The information contained in the manual can be changed without notice. Potential damages caused in relation to the use of these instructions will not be considered because these are only indicative. Remember that the non observance of the indications reported by us might cause damage to persons or things. It is understood, that local dispositions and/or laws must be respected.

WARNING



Situations of danger - no harm to persons or things

Do not use without protective devices provided

Removing or disabling protective devices on the machine is prohibited.

Do not use the machine if it is not in good technical condition

The machine must be in good working order before being used. Defects, especially those which regard the safety of the machine, must be repaired before using the machine.

SAFETY PRECAUTIONS



DANGEROUS

This heading warns of an immediate danger for persons as well for things. Not following the advice can result in serious injury or death.



WARNING

This heading warns of situations which could result in injury for persons or damage to things.



CAUTION

To this advice can appear a danger for persons as well as for things, for which can appear situations bringing material damage to things.



IMPORTANT



NOTE



ATTENTION

These headings refer to information which will assist you in the correct use of the machine and/or accessories.

SYMBOLS



STOP - Read absolutely and be duly attentive



Read and pay due attention



GENERAL ADVICE - If the advice is not respected damage can happen to persons or things.



HIGH VOLTAGE - Attention High Voltage. There can be parts in voltage, dangerous to touch. The non observance of the advice implies life danger.



FIRE - Danger of flame or fire. If the advice is not respected fires can happen.



HEAT - Hot surfaces. If the advice is not respected burns or damage to things can be caused.



EXPLOSION - Explosive material or danger of explosion. in general. If the advice is not respected there can be explosions.



WATER - Danger of shortcircuit. If the advice is not respected fires or damage to persons can be caused.



SMOKING - The cigarette can cause fire or explosion. If the advice is not respected fires or explosions can be caused.



ACIDS - Danger of corrosion. If the advice is not respected the acids can cause corrosions with damage to persons or things.



WRENCH - Use of the tools. If the advice is not respected damage can be caused to things and even to persons.



PRESSION - Danger of burns caused by the expulsion of hot liquids under pressure.



ACCES FORBIDDEN to non authorizad people.

PROHIBITIONS No harm for persons

Use only with safety clothing -



It is compulsory to use the personal protection means given in equipment.

Use only with safety clothing -



It is compulsory to use the personal protection means given in equipment.

Use only with safety protections -



It is a must to use protection means suitable for the different welding works.

Use with only safety material -



It is prohibited to use water to quench fires on the electric machines.

Use only with non inserted voltage -



It is prohibited to make interventions before having disinserted the voltage.

No smoking -



It is prohibited to smoke while filling the tank with fuel.

No welding -



It is forbidden to weld in rooms containing explosive gases.

ADVICE No harm for persons and things

Use only with safety tools, adapted to the specific use -

It is advisable to use tools adapted to the various maintenance works.

Use only with safety protections, specifically suitable



It is advisable to use protections suitable for the different welding works.

Use only with safety protections -



It is advisable to use protections suitable for the different daily checking works.

Use only with safety protections -



It is advisable to use all protections while shifting the machine.

Use only with safety protections -



It is advisable to use protections suitable for the different daily checking works.and/or of maintenance.

 The installation and the general advice concerning the operations, are finalized to the correct use of the machine, in the place where it is used as generator group and/or welder.

| | | | |
|---|---|-----------------------|--|
| ENGINE | Stop engine when fueling | CHECKING BOARD | Do not touch electric devices if you are barefoot or with wet clothes. |
| | Do not smoke, avoid flames, sparks or electric tools when fueling. | | Always keep off leaning surfaces during work operations. |
| | Unscrew the cap slowly to let out the fuel vapours. | | Static electricity can damage the parts on the circuit. |
| | Slowly unscrew the cooling liquid tap if the liquid must be topped up. | | An electric shock can kill |
| | The vapor and the heated cooling liquid under pressure can burn face, eyes, skin. | | |
| | Do not fill tank completely. | | |
| | Wipe up spilled fuel before starting engine. | | |
| | Shut off fuel of tank when moving machine (where it is assembled). | | |
| | Avoid spilling fuel on hot engine. | | |
| Sparks may cause the explosion of battery vapours | | | |



FIRST AID. In case the operator should be sprayed by accident, from corrosive liquids a/o hot toxic gas or whatever event which may cause serious injuries or death, predispose the first aid in accordance with the ruling labour accident standards or of local instructions.

| | |
|-------------------------------|--|
| Skin contact | Wash with water and soap |
| Eyes contact | Irrigate with plenty of water, if the irritation persists contact a specialist |
| Ingestion | Do not induce vomit as to avoid the intake of vomit into the lungs, send for a doctor |
| Suction of liquids from lungs | If you suppose that vomit has entered the lungs (as in case of spontaneous vomit) take the subject to the hospital with the utmost urgency |
| Inhalation | In case of exposure to high concentration of vapours take immediately to a non polluted zone the person involved |



FIRE PREVENTION. In case the working zone, for whatsoever cause goes on fire with flames liable to cause severe wounds or death, follow the first aid as described by the ruling norms or local ones.

| EXTINCTION MEANS | |
|-----------------------|--|
| Appropriated | Carbonate anhydride (or carbon dioxide) powder, foam, nebulized water |
| Not to be used | Avoid the use of water jets |
| Other indications | Cover eventual shedding not on fire with foam or sand, use water jets to cool off the surfaces close to the fire |
| Particular protection | Wear an autorespiratory mask when heavy smoke is present |
| Useful warnings | Avoid, by appropriate means to have oil sprays over metallic hot surfaces or over electric contacts (switches, plugs, etc.). In case of oil sprinkling from pressure circuits, keep in mind that the inflammability point is very low. |

| WARNING | | | | | CAUTION | | DANGEROUS |
|---------|--|--|--|--|---------|--|-----------|
| | | | | | | | |
| | | | | | | | |

| | |
|--------------------|---|
| WARNING | THE MACHINE <u>MUST NOT BE USED</u> IN AREAS WITH EXPLOSIVE ATMOSPHERE |
|--------------------|---|



General installation criteria

Installation of a genset has to be planned by qualified and trained technicians, it has to be carried out by a competent organization with qualified personnel and proper equipment.



ATTENTION

Faulty installation can create damage to the genset and the User system, and injury to persons. It is compulsory to install the genset according to the norms in force in the country of installation.

The installing company must provide a conformity declaration stating that installation has been carried out duly and according to plans and to norms in force.

Before proceeding with installation the following conditions have to be checked:

- Genset has been selected according to needs of the electrical load and to environmental conditions (temperature, altitude and humidity);
- Genset location is of appropriate dimensions and allows accessibility to genset for maintenance and/or necessary repairs;
- If genset is indoors, ensure there is enough air for engine combustion, for genset cooling (radiator and generator), and sufficient ventilation;
- If genset is indoors, a system of expulsion for engine exhaust gas is provided;
- Personnel safety has been carefully considered;
- Noise-level issues have been carefully considered;
- Fuel and lubricant stocking issues have been considered in accordance to norms in force in the country of installation.



INFORMATION

Italian and European norms define specific characteristics referring to the premises in which genset should be located, indicating possible positioning, minimum dimensions, etc.

For any doubt referring to installation location contact our technical sales office.

Outdoor installation



ATTENTION

All generating sets are equipped with a control system that is NOT influenced by standard environmental factors and is able to stop the unit in case of anomalous values in the fundamental parameters.

In order to avoid unexpected black-outs or other potentially dangerous situations, the below installation indications must be followed.

Environmental conditions



ATTENTION



Open gensets (SKID) have to be located in an area protected from rain, snow, high humidity and direct exposure to the sun.

Rain or high humidity on GE genset alternator, in particular during operation, cause an increase in voltage output, winding faults, electric discharge towards ground, with damage to the genset and injury to persons. Dust, in particular saline dust, must be avoided. In case radiator or air filters are obstructed, there is the risk that genset will overheat or be damaged. Aspiration grills must not be obstructed by leaves, snow, etc.

Output of fumes in open air conditions



DANGER





Genset must be positioned so that exhaust gas is diffused without being inhaled by any living being.

Engine exhaust gas contains carbon monoxide, which is harmful to one's health, and in big quantities can cause intoxication and death.

Local norms in force have to be respected.



Safe distance

 **ATTENTION** 

A safe distance has to be kept between genset and fuel deposits, inflammable goods (cloths, paper, etc.), chemicals, according to indications provided by the authority in charge. In order to avoid potentially dangerous situations, area surrounding genset should be isolated so that unauthorized people will not be able to get close to the unit. Even if MOSA gensets are manufactured according to electromagnetic compatibility norms, we suggest NOT to install the genset near machinery that can be influenced by magnetic fields.

Fixing



In order to absorb vibrations produced by genset, it should be fixed to a surface with sufficient rigidity, isolated against vibrations towards other structures and with a mass equal to at least three times the genset mass. DO NOT locate the genset on terraces or raised levels, if its characteristics have not been previously verified as suitable.

 **NOTE** 

When using a genset it is advisable to adopt precautions to avoid that fuel, lubricant and other engine liquids may accidentally cause soil pollution. The most recent generators are designed to retain possible liquid leakages, hence no specific measures are needed in this regard. In case of doubts concerning your genset do not hesitate to contact our technical sales office.

Fixed outdoor installation

If a shelter is used to protect the genset (see figure), it should NOT be attached to it. Even if a shelter is temporary the below indications should be followed:

  **ATTENTION** 

Engine and alternator when in operation produce heat:

- Shelter should NOT obstruct normal cooling of components;
- Exhaust gas should be directed in order to avoid the possibility that alternator and engine fan inhale it;
- Shelter should be made of fireproof material, as embers may come out of the exhaust pipe;
- Never cover or wrap up genset with plastic sheets or other material while operating. If genset is off, make sure engine has cooled before you cover it, or else there may be risk of damage to the genset or may catch fire.

Temporary outdoor installation

Indications given for fixed installation have to be followed.

If genset is not positioned correctly, vibrations transmitted to the baseframe may cause the genset to move, this may occur while the genset has a load inserted, take on all necessary precautions to avoid this.

Sample of outdoor installation with shelter

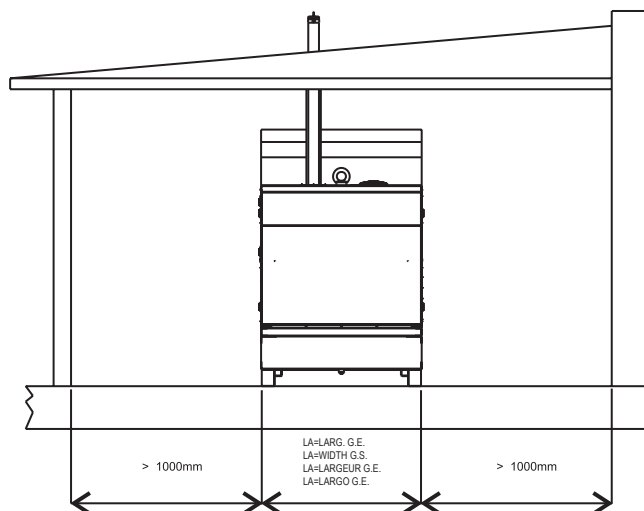

Sample of outdoor installation with shelter

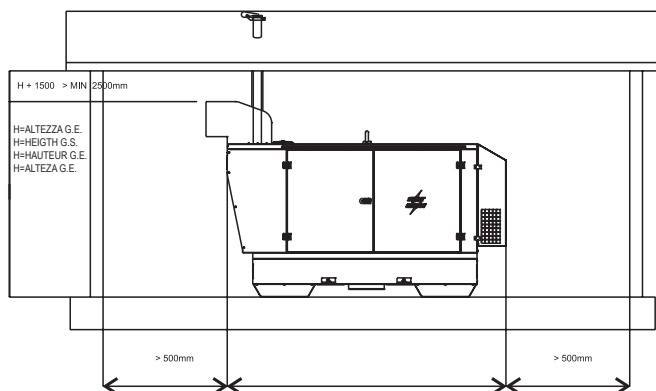

Floor should be levelled and suitable to sustain genset weight.

Thresholds on doors and openings should have a barrier in order to avoid liquids leaking. In case it is not possible to provide a door with a barrier, the genset should have a collection base appropriate for the quantity of liquid it contains, in any case dimensions of collection base must be in accordance to the laws in force in country of installation.

Indoor installation

In order to avoid endangering or damaging genset following indications must be followed.

Genset installation location has to be in accordance to the norms in force.

| ref. | Description |
|------|--|
| 1 | Generating set |
| 2 | Auxiliary aspirator |
| 5 | Exhaust pipe |
| 7 | Exhaust pipe protection and insulation |
| 8 | Raincover and anti-intrusion grid |
| 9 | Exhaust conduit |
| 11 | Location area with isolated foundation |
| 12 | Air inlet with anti-intrusion grid |
| 13 | Entrance door |
| 14 | Containment step |

| Minimum suggested dimension table | |
|---|----------------------------------|
| A | Length G.E. + 1000 mm |
| B | Width G.E. + 2000 mm |
| C | Width G.E. + 200 mm |
| D | Length G.E. + 400 mm |
| E | Width G.E. + 400 mm |
| H | Height G.E. + 1500 mm (>2500 mm) |
| Note: dimensions required by norms in force have to be respected in any case. | |

Surface area

The best solution is to create a base isolated from the rest of the structure, on which the genset will be located, in order to avoid vibrations being transmitted.

The base must be built with reinforced concrete and there must be the possibility to fix the genset to it by using screw anchors or rag bolts.

Base dimensions should exceed genset dimensions of at least 200 mm on each side. Base should weigh three times static genset weight (indicated on the technical date).

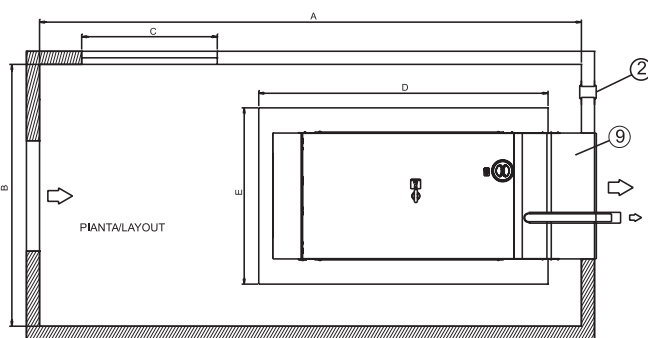
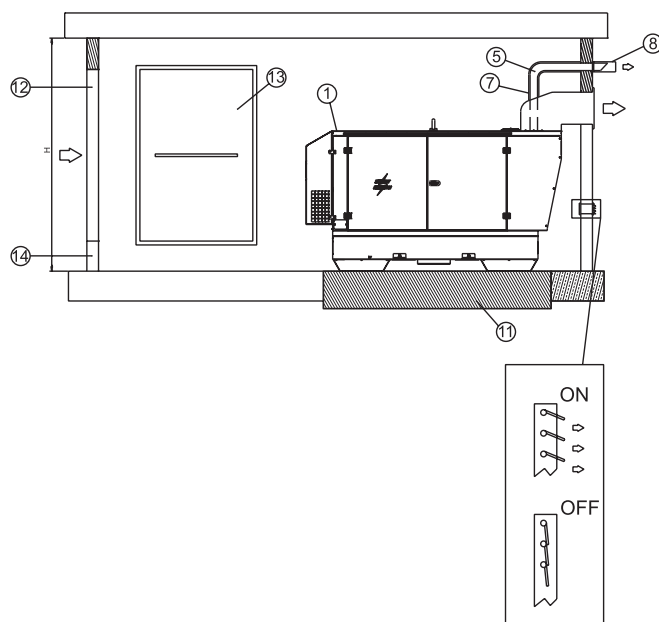

Room openings and ventilation

The room should have a ventilation system sufficient enough to avoid stagnation and circulation of overheated air.

Openings for incoming and outgoing air should be of appropriate size, considering minimum required air flow and maximum back pressure, values that can be checked on the engine manual.

Opening for the air entrance should be near the back part of the genset as close as possible to the ground. If openings for air flow are not aligned with genset it may be necessary to add air conduits to avoid any air dispersion (see figure).

For open gensets installed indoors, we recommend:

- The dimensions of the air outlets be such that they have at least the same area of the radiator;
- the dimensions of the windows for air outlet is at least on the surface of the radiator.
- The dimensions of the air inlets be such that they have at least the same area of the radiator +10% for gensets up to 130 kVA or +25% for gensets beyond 130 kVA;

For canopied gensets installed indoors, we recommend:

- The dimensions of the air outlets be such that they have at least the same area of the generator air outlets, as indicated at page M2.7 of the present manual;
- The dimensions of the air inlets be such that they have at least the same area of the generator air inlets, as indicated at page M2.7 of the present manual +10% for gensets up to 130 kVA or +25% for gensets beyond 130 kVA;

The opening area has to be calculated considering protection grill surface, in order to insure that remaining free area is sufficient.

Dimensions of openings calculated as above indicated, are the minimum acceptable dimensions in case of L.T.P. use; the pressure remaining after radiator and back pressure must be considered while planning dimensions of the piping.

To calculate the opening section check below drawing:

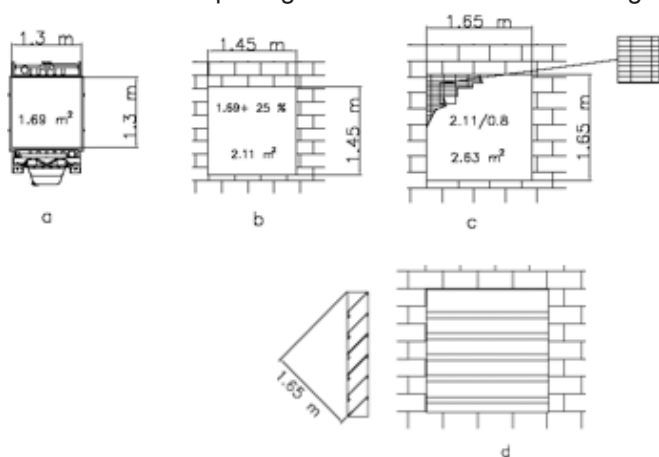

| | |
|---|---|
| a | Radiator surface |
| b | Free opening |
| c | Air flow opening with grill and 80% of open surface |
| d | Air flow opening with baffle plates |

WARNING: to avoid reflux of heated air and loss of load, add an air duct between radiator and opening.

To consider the correct quantity of heat to be discharged, loss of heat on duct should be evaluated. If the duct is not appropriately insulated, room-temperature may increase considerably, for this reason it may be necessary to install an electro ventilator for correct air exchange.

Electro ventilator capacity can be calculated as follows:

$$Fan\ Capacity\ [m^3/h] = \frac{Transmitted\ heat\ [Kcal/h]}{0,287 \times \Delta t\ [^{\circ}C]}$$

Considering:

- heat to radiation is indicated on engine/alternator technical data sheet;
- 0.287 is specific heat for each m3 of air at 20°C;
- Δt in °C is usually considered as equal to 5 °C (worst conditions are considered).

Exhaust piping

Exhaust piping must be built in accordance to laws in force in the country of installation.

General indications:

- Minimum required thickness: 2.0 mm;
- Diameter of piping has to be calculated considering, length, number of bends, type of exhaust muffler, and any other accessory used on it. **Back pressure should not exceed values provided by manufacturer, as this causes loss of power and damage to the engine.**

ATTENTION

Exhaust piping may reach up to 600 °C during operation, therefore it is compulsory to cover piping with appropriate insulation.

- Exhaust piping should be composed of parts, connected by flanges with gaskets, for easy disassembling and grant maximum tightness.
- Exhaust piping should be connected to engine by a flex that should absorb dilatation and separate fix part from engine piping.
- Exhaust piping should not weigh on engine manifold.

DANGER

Engine exhaust gas contains carbon monoxide, harmful to health and in large quantities can cause intoxication or death.

I INSTALLAZIONE
GB INSTALLATION
F INSTALLATION

D LUFTZIRKULATION
E INSTALACIÓN
PT

GE 8 YSX
GE 10 YSX
GE 15 YSX

M
2.7
REV.0-09/12

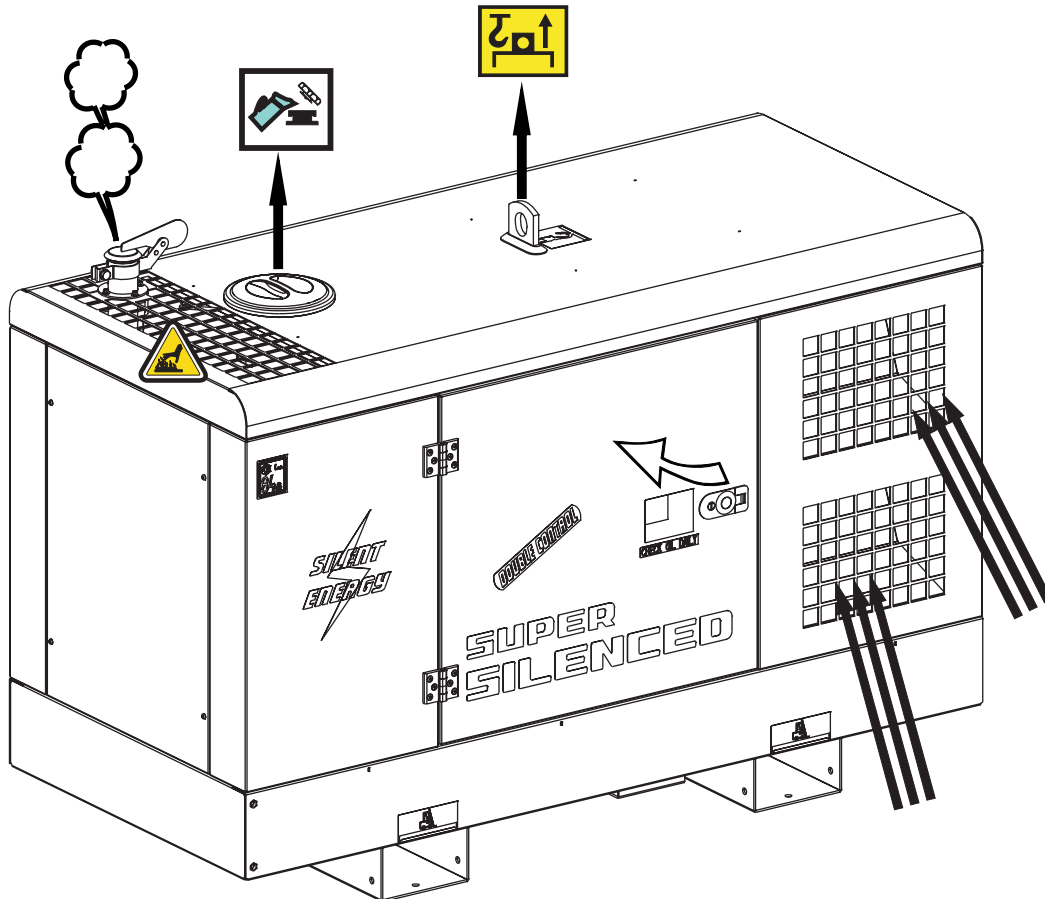
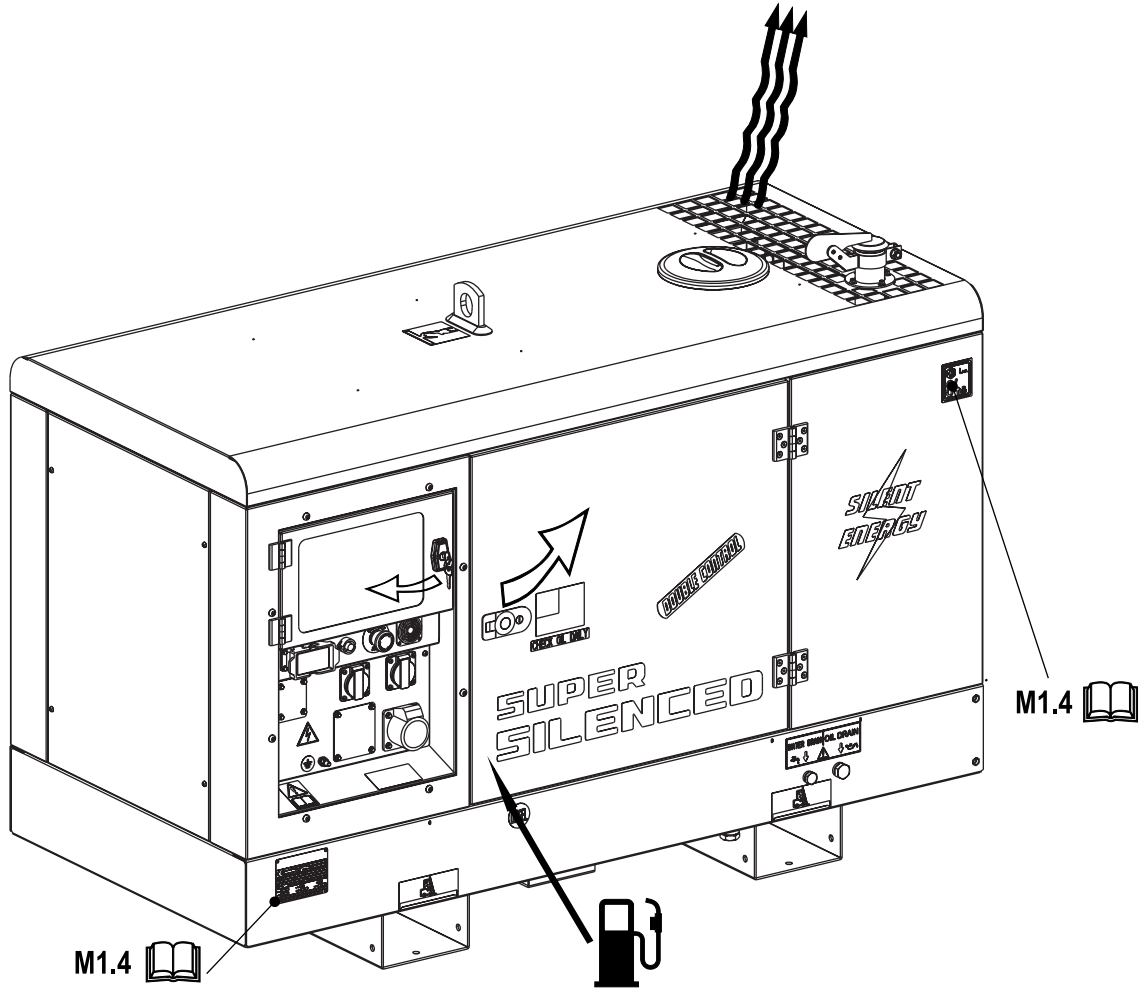

(I) DIMENSIONI (D) ABMESSUNGEN
 (GB) DIMENSIONS (E) DIMENSIONES
 (F) DIMENSIONS (PT)

GE 8 YSX
 GE 10 YSX
 GE 15 YSX

M
 2.7.1
 REV.0-09/12

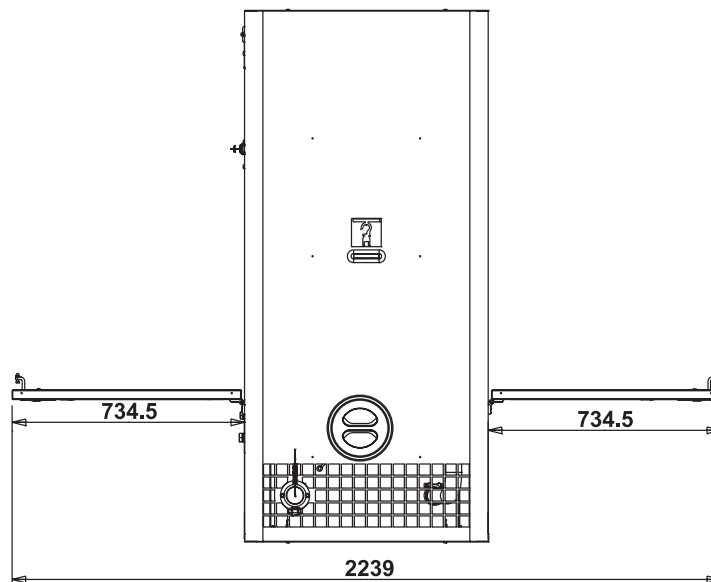
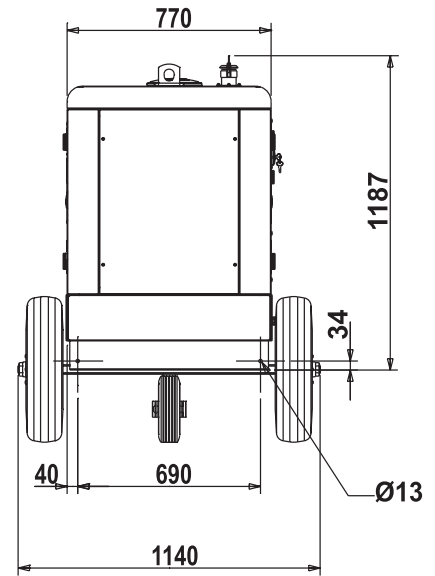
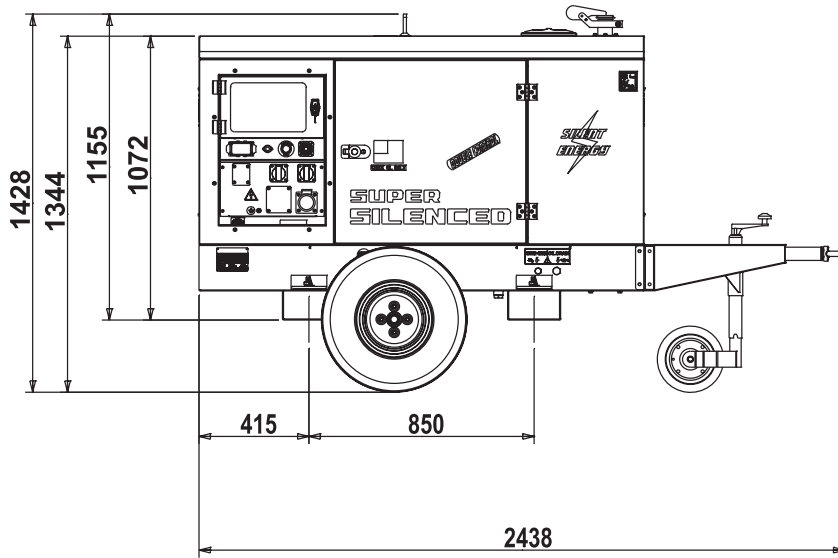
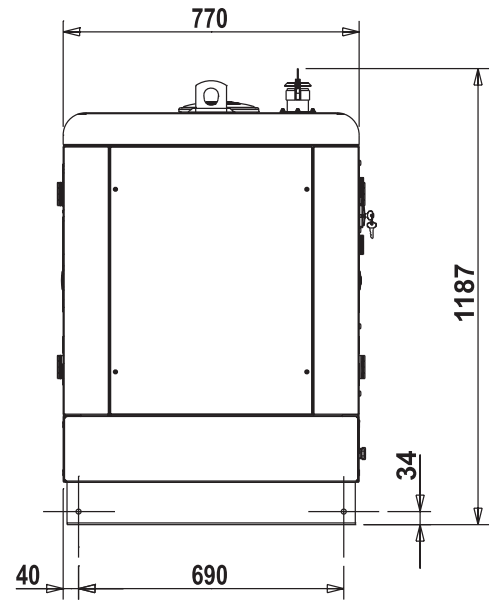
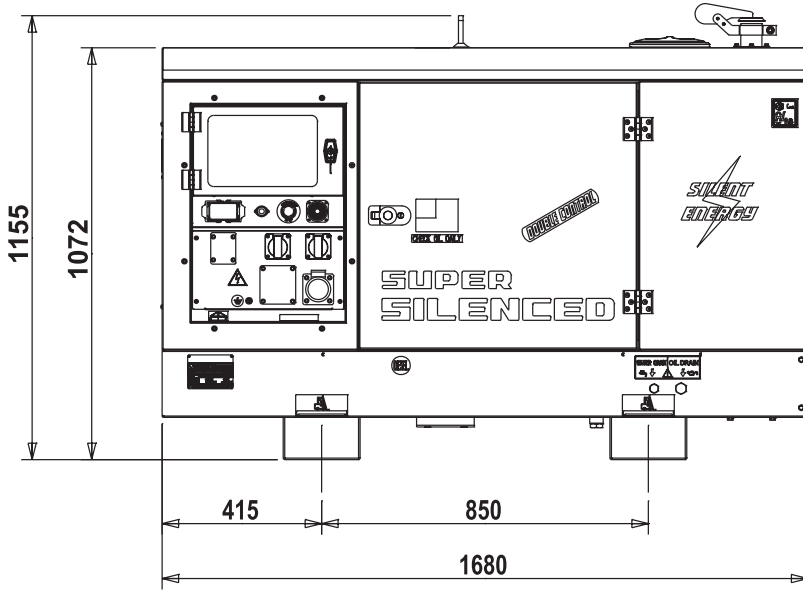

 **NOTE**

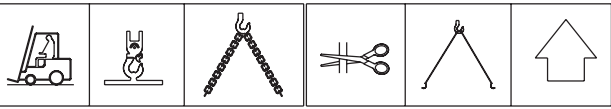

Be sure that the lifting devices are: correctly mounted, adequate for the weight of the machine with its packaging, and conforms to local rules and regulations. When receiving the goods make sure that the product has not suffered damage during the transport, that there has not been rough handling or taking away of parts contained inside the packing or in the set. In case you find damages, rough handling or absence of parts (envelopes, manuals, etc.), we advise you to inform immediately our Technical Service.

For eliminating the packing materials, the User must keep to the norms in force in his country.

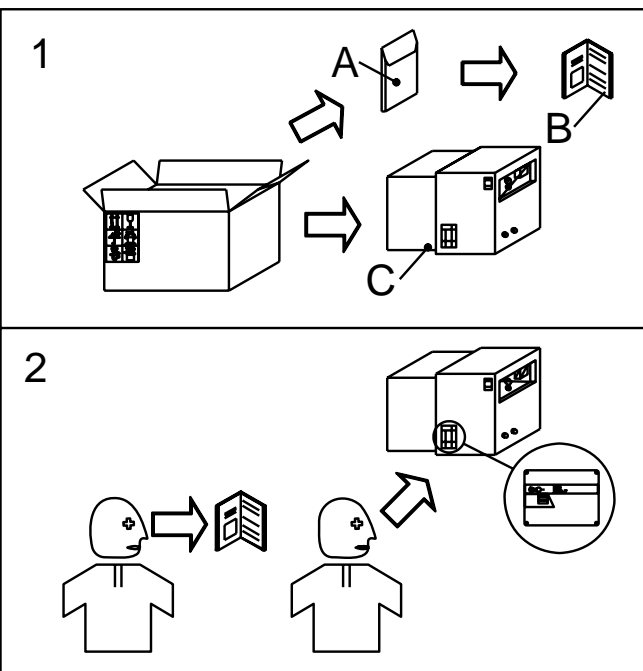
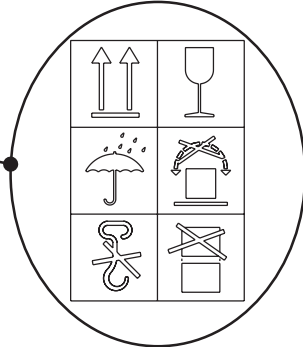
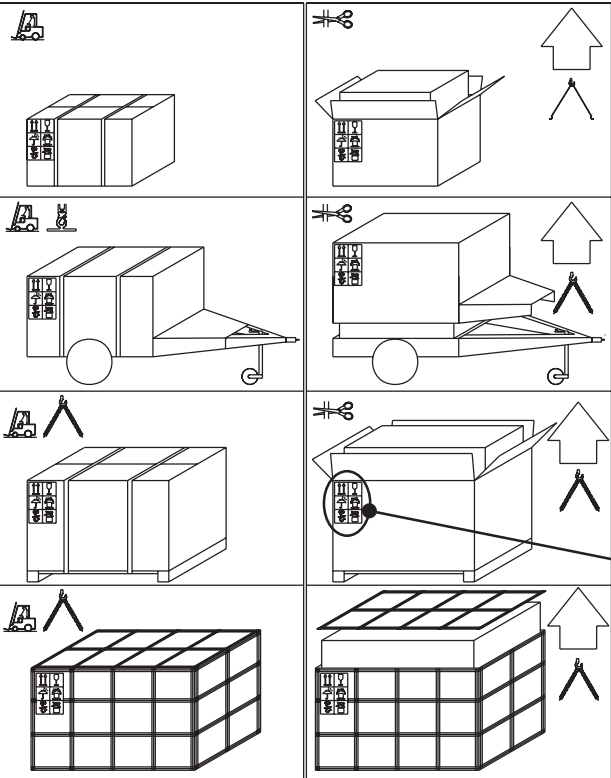

- 1) Take the machine (C) out of the shipment packing. Take out of the envelope (A) the user's manual (B).
- 2) Read: the user's manual (B), the plates fixed on the machine, the data plate.

General precautions when handling the machine.

ATTENTION

When moving/lifting a genset it is imperative to be extremely careful. All moving operations must be carried out by qualified persons.

Due to the weight and encumbrance of the genset, an error while moving/lifting the unit may cause serious damage to it or surrounding persons.

To limit the dangers involved in moving a generating set, it is important to carefully follow the guideline set out below:

- Transportation must always take place with the engine off and electrical cables and starting battery disconnected and fuel tank empty.
- Particular attention must be paid to SKID version generating sets (without canopy) that have very delicate parts unprotected from bumps (injection pump, speed regulator, radiator, electrical panel connections and instrumentation).
- Generating sets must be protected from bad weather during transport: the units must be entirely covered, especially the electrical parts (alternator and control panel).
- Some engine parts retain heat even after it has been shut off: therefore it is necessary to wait for the engine to cool before covering it to avoid the risk of fire.
- Clear the moving zone of all possible obstacles and from all unnecessary personnel.
- Use properly sized lifting equipment regularly submitted to major overhaul by an authorized organisation. It is prohibited to fasten objects or accessories on the generating set baseframe that may modify weight and center of gravity and may cause movements unforeseen by the lifting eyes.
- Do not subject the generating set and lifting equipment to abrupt or undulating movements that pass on stress dynamics to the structure.
- Do not lift the generating set higher than what is absolutely necessary.
- Transportation of separate manual or automatic control panels must be carried out very carefully in order to avoid damage to the equipment contained inside the panel and to the instruments on the front.
- To access the hook points on the top of the unit, use approved ladders only or support from another operator: climb the ladder using non-skid shoes.

Moving method

The generating sets are lifted with different methods according to the unit's configuration. Below are the main methods of moving/lifting the genset.

Moving the generating set via forklift

When lifting with a forklift it is necessary to fork the baseframe sideways so that the forks stick out from one side to the other side, widening them to distribute the weight properly, maintaining the genset level. Stickers on the base indicate where to place the lifter forks.

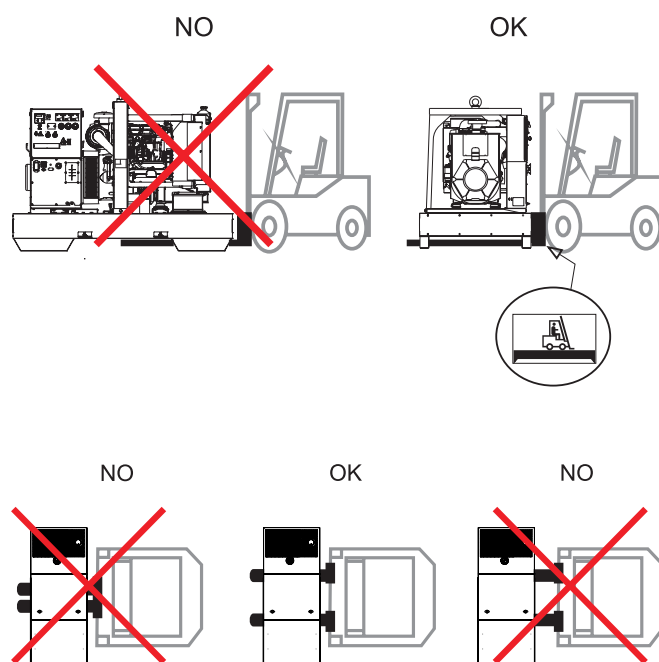

Moving the generating set via cables or chains

When lifting the genset with the aid of cables or chains it is necessary to use equipment periodically checked by a licensed organisation. Hook the cables only on to the points provided for this use and shown via the appropriate stickers.

For correctly moving the generating set:

- DO NOT lift the genset by fastening cables to the lifting eyes on the engine or alternator (these are only used for lifting the single components).
- DO NOT make abrupt or undulating movements that pass on stress dynamics to the structure.
- DO NOT leave the generating set suspended for longer than absolutely necessary to move the unit.
- Use all the lifting eyes provided.
- Use cables and/or chains of equal length so that the weight is distributed evenly.

Moving the generating set via cables or chains

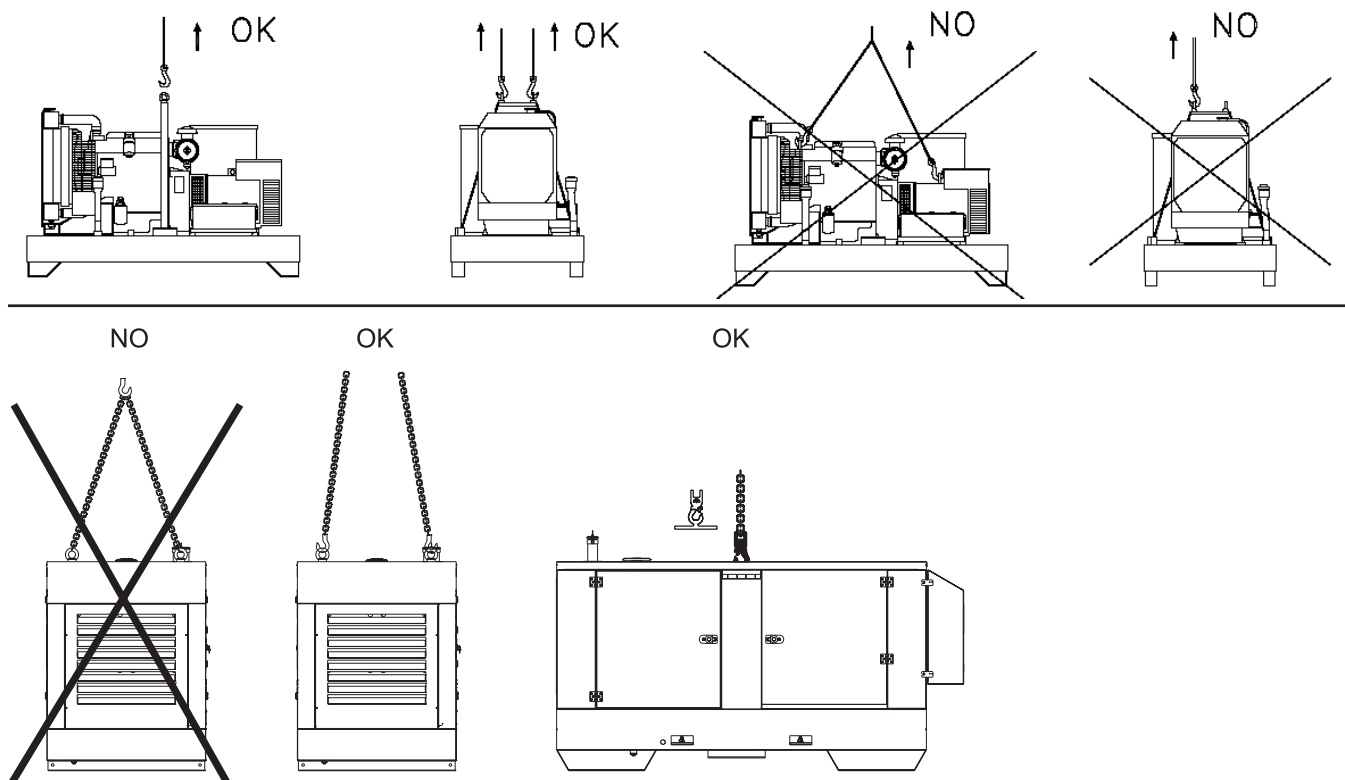

Moving by site trolley / trailer

BEWARE

DO NOT TOW the generating set without trailer, be it manually or using a vehicle.

Trolleys/trailers should only be used to move the generating set for which they were designed.

Road trolley CTV:

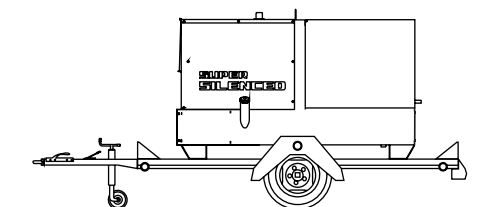

made by using a general use standard trailer on which the genset is fixed: it is type approved for transport on public roads by licensed organisations. The maximum speed allowed is 80 km/h however, the transportation laws in force in the place of use should be respected.

Site tow CTL:

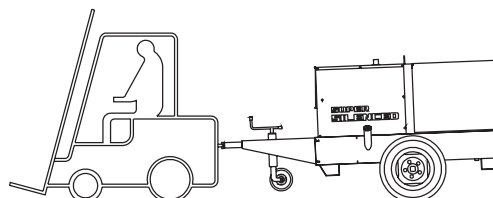

this trailer is made by the manufacturer and connected to the generating set baseframe, it can not be towed on public roads. Therefore it can only be used on private roads and no through traffic zones.

The maximum speed allowed is 40 km/h on smooth surfaces (asphalt, cement) and, in any case, the laws in force in the place of use should be respected.

Always follow the directions below for any tipe of tow:

- DO NOT park the generating set/trolley assy, on slant ground
- When parking always use the emergency/hand brake and/or safety clamps.
- DO NOT tow the trailer on bumpy roads.

Moving the unit via motor vehicle

During transportation with a motor vehicle, it is important to use appropriate belts/straps to stabilise the unit, therefore avoiding that unexpected bumps or jolts can cause damage to the baseframe, engine, or worse, overturn the load. It is the carrier's responsibility to always respect the highway code in force.



⚠ ATTENTION

The CTL accessory cannot be removed from the machine and used separately (actioned manually or following vehicles) for the transport of loads or anyway for used different from the machine movements.

TRAILERS

The machines provided for assembling the accessory (slow towing trolley) can be towed up to a **maximum** speed of **40 Kms/hour** on asphalted surfaces.

Towing on public roads or turnpikes of any type **IS EXCLUDED**, because **not** in possession of the requirements by national and foreign traffic norms.

Nota: Lift the machine and assemble the parts as shown in the drawing

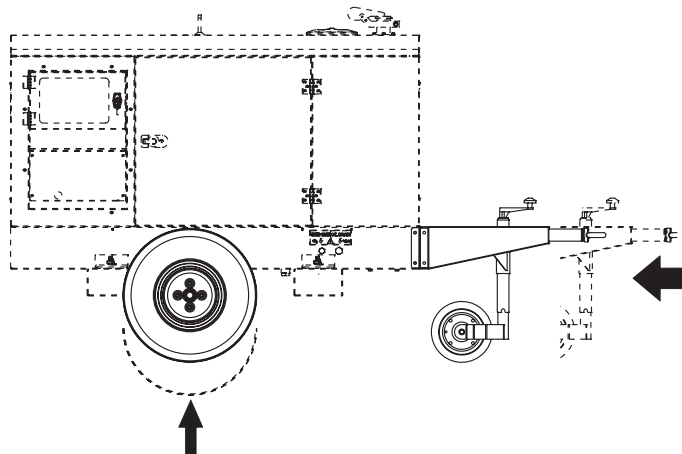

For assembling the generating set on the trolley CTL15 please keep to following instructions:

- 1) - Lift the generating set (by means of suitable hook).
- 2) - Slightly fix the jaw (3) of the parking foot to the bar with the M10x20 screws, the M10 nuts and the washers (so as to let the foot sprag go through).
- 3) - Split (unscrewing them) the two parts of the foot (4S-4I) to be able later to assemble them on the jaw.
- 4) - Introduce into the jaw (3) the upper part (4S) of the foot and screw again the lower part (4I), then tighten the screws (4V) of the jaw to the towbar and block momentarily with the lever (4L) the whole foot.
- 5) - Assemble on the machine the towbar (5) complete of foot with the M10x20 and M10x25 screws, nuts and washers.
- 6) - Assemble the axle (7) to the base of the machine with the M10x25 screws and relative washers (two per part) so that their supports coincide.
- 8) - Insert the wheel (9) on the axle then screw the self blocking nuts (8).
- 9) - Pump the tyre (9) bringing the pressure to four atms.
- 10) - Lower the machine to the ground and place the parking foot definitively (regulating at the best height).

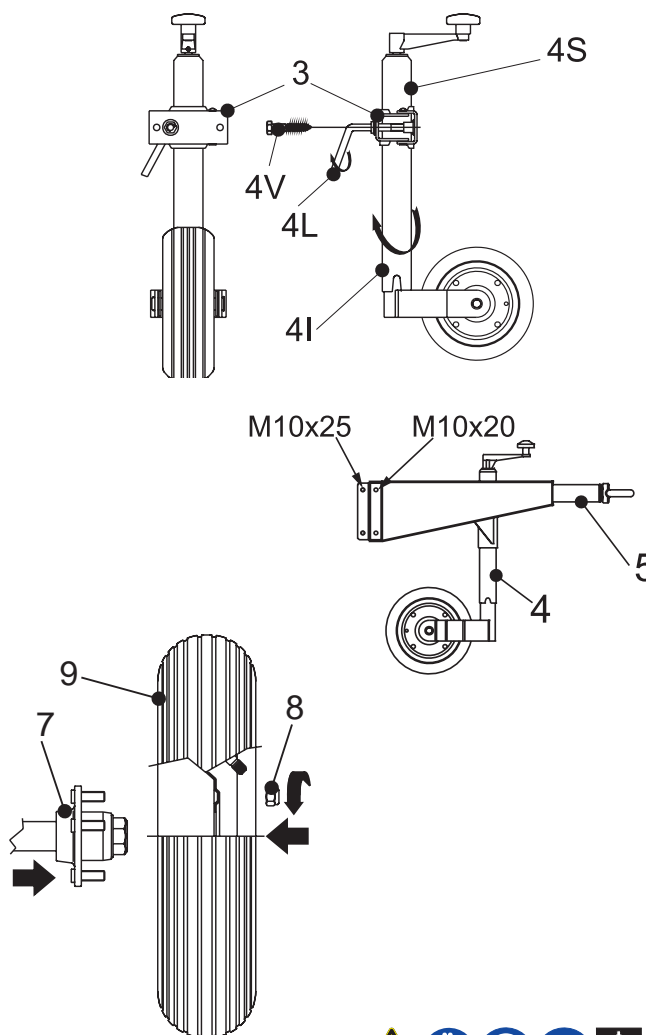

⚠ ATTENTION

Do not substitute the original tires with other types.



I

GB Set-up for operation

F

Water cooled systems

M
20

REV.1-09/05

**BATTERY WITHOUT MAINTENANCE**

Connect the cable + (positive) to the pole + (positive) of the battery (after having taken away the protection), by properly tightening the clamp.

Check the state of the battery from the colour of the warning light which is in the upper part.

- Green colour: battery OK
- Black colour: battery to be recharged
- White colour: battery to be replaced

DO NOT OPEN THE BATTERY.

**LUBRICANT****RECOMMENDED OIL**

MOSA recommends selecting **AGIP** engine oil. Refer to the label on the motor for the recommended products.

|  PRODOTTI RACCOMANDATI RECOMMENDED PRODUCTS | |
|--|---|
| AGIP SIGMA TURBO PLUS 15W/40 API CG4 - ACEA E3 | OLIO MOTORE DIESEL DIESEL ENGINE OIL |
| AGIP SUPERMOTOROIL 20W/50 API CC-SF | OLIO MOTORE BENZINA GASOLINE ENGINE OIL |
| AGIP ANTIFREEZE EXTRA INIBITE ETHYLENE GLYCOL (50% + 50% + H ₂ O) | CIRCUITO DI RAFFREDDAMENTO COOLING CIRCUIT (CUNA NC 956-16 ED 97) |

Please refer to the motor operating manual for the recommended viscosity.

REFUELLING AND CONTROL:

Carry out refuelling and controls with motor at level position.

1. Remove the oil-fill tap (24)
2. Pour oil and replace the tap
3. Check the oil level using the dipstick (23); the oil level must be comprised between the minimum and maximum indicators.

**AIR FILTER**

Check that the dry air filter is correctly installed and that there are no leaks around the filter which could lead to infiltrations of non-filtered air to the inside of the motor.

**FUEL****ATTENTION**

Do not smoke or use open flames during refuelling operations, in order to avoid explosions or fire hazards.

Fuel fumes are highly toxic; carry out operations outdoors only, or in a well-ventilated environment.



Avoid accidentally spilling fuel. Clean any eventual leaks before starting up motor.

Refill the tank with good quality diesel fuel, such as automobile type diesel fuel, for example.

For further details on the type of diesel fuel to use, see the motor operating manual supplied.

Do not fill the tank completely; leave a space of approx. 10 mm between the fuel level and the wall of the tank to allow for expansion.

In rigid environmental temperature conditions, use special winterized diesel fuels or specific additives in order to avoid the formation of paraffin.

**ATTENTION**

It is dangerous to fill the motor with too much oil, as its combustion can provoke a sudden increase in rotation speed.





COOLING LIQUID



ATTENTION



Do not remove the radiator tap with the motor in operation or still hot, as the liquid coolant may spurt out and cause serious burns. Remove the tap very carefully.

Remove the tap and pour the liquid coolant into the radiator; the quantity and composition of the liquid coolant are indicated in the motor operating manual. Replace the tap, ensuring it is perfectly closed. After refilling operations, allow the motor to run for a brief time and check the level, as it may have diminished due to air bubbles present in the cooling circuit; restore the level with water. To replace the liquid coolant, follow the operations described in the motor operating manual.

ATTENTION:

The engine cooling system is originally filled with coolant type:

AGIP ANTIFREEZE EXTRA

During the engine life it is strongly recommended to use the same coolant type. This is because a coolant change would require a careful cleaning of the cooling system, which is not an easy job. A lack in tacking these precautions would result in the mix of different additives used in different coolants which would originate gelatinous substances capable of obstructing the cooling system.



GROUNDING CONNECTION

The grounding connection to an earthed installation **is obligatory** for all models equipped with a differential switch (circuit breaker). In these groups the generator star point is generally connected to the machine's earthing; by employing the TN or TT distribution system, the differential switch guarantees protection against indirect contacts.

In the case of powering complex installations requiring or employing additional electrical protection devices, the coordination between the protection devices must be verified.

For the grounding connection, use the terminal (12); comply to local and/or current regulations in force for electrical installations and safety.

|  PRODOTTI RACCOMANDATI RECOMMENDED PRODUCTS | |
|--|---|
| AGIP SIGMA TURBO PLUS 15W/40 API CG4 - ACEA E3 | OLIO MOTORE DIESEL DIESEL ENGINE OIL |
| AGIP SUPERMOTOROIL 20W/50 API CC-SF | OLIO MOTORE BENZINA GASOLINE ENGINE OIL |
| AGIP ANTIFREEZE EXTRA INIBITE ETHYLENE GLYCOL (50% + 50% + H ₂ O) | CIRCUITO DI RAFFREDDAMENTO COOLING CIRCUIT (CUNA NC 958-16 ED 97) |





Check daily



NOTE

Do not alter the primary conditions of regulation and do not touch the sealed parts.

The starting of the unit can be effected in 3 different modes:

1) Start with EP6 key (Engine Control)

Put the "Local/Remote" selector on Local. Turn the key on "ON", the EP6 display shows, only on the machines with mounted glow plugs for 5 secs, the symbol "UUUU", then the message "Sta" appears the engine can be started, for then turn the key on "start" and start the engine.

On the display the word "Sta" remains for about 20 sec then automatically disappears; the engine **must be** started within 20 secs, otherwise the EP6 blocks the starting and on the display the word "fail" appears. Turning the key on "OFF" the EP6 is reset and a new starting cycle can be fixed.

Stop:

it is COMPULSORY to disconnect the load first, then to stop the engine turn the key on "OFF".

2) Remote starting with TCM35

Put the "Local/Remote" selector on Local. Connect TCM35 to the plug on the front panel and put the switch on "0".

Turn the key on ON in the EP6, wait for the various signals to go out then press the button "AUTO" in the EP6 until the led "AUTO" flashes.

Shift the switch on "1" in the TCM35 and automatically the starting cycle will start. On the machines with mounted glow plugs appears in the display EP6 (for about 5 secs), the symbol "UUUU"; the starting cycle includes 3 starting trials.

When the engine starts the led "AUTO" remains lit continuously and simultaneously the red warning light will light in the TCM35.

Stop:

it is COMPULSORY to disconnect the load first, then shift the switch of the TCM35 on "0", the engine will stop immediately.

3) Start with Automatic start unit (EAS)

Put the "Local/Remote" selector on Remote. Connect the EAS to unit.

The EAS controls the starting as well as the stop of the engine.

Follow attentively the instructions reported in the EAS manual. In these conditions the EP6 has the only function to measure the electric values, hour-meter, etc.



CAUTION

MACHINE WITH EMERGENCY BUTTON

Pressing the button the engine will stop immediately in any working condition.



Turn clockwise to reset the button.

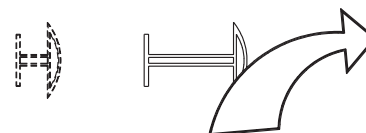

CAUTION

RUNNING-IN

During the first 50 hours of operation, do not use more than 60% of the maximum output power of the unit and check the oil level frequently, in any case please stick to the rules given in the engine use manual.



NOTE

For safety reason the key must be kept by qualified personel.

| | | | | | |
|-----|--|----|--|----|--|
| 4A | Hydraulic oil level light | B4 | Exclusion indicating light PTO HI | W5 | Battery voltmeter |
| 9 | Welding socket (+) | B5 | Auxiliary current push button | X1 | Remote control socket |
| 10 | Welding socket (-) | C2 | Fuel level light | Y3 | Button indicating light 20 l/1' PTO HI |
| 12 | Earth terminal | C3 | E.A.S. PCB | Y5 | Commutator/switch, serial/parallel |
| 15 | A.C. socket | C6 | Control unit for generating sets QEA | Z2 | Thermal-magnetic circuit breaker |
| 16 | Accelerator lever | D | Ground fault interrupter (30 mA) | Z3 | Selection push button 20 l/1' PTO HI |
| 17 | Feed pump | D1 | Engine control unit and economiser EP1 | Z5 | Water temperature indicator |
| 19 | 48V D.C. socket | | | | |
| 22 | Engine air filter | D2 | Ammeter | | |
| 23 | Oil level dipstick | E2 | Frequency meter | | |
| 24 | Engine oil reservoir cap | E6 | Frequency rpm regulator | | |
| 24A | Hydraulic oil reservoir cap | E7 | Voltmeter regulator | | |
| 24B | Water filling cap | F | Fuse | | |
| 25 | Fuel prefilter | F3 | Stop switch | | |
| 26 | Fuel tank cap | F5 | Warning light, high temperature | | |
| 27 | Muffler | F6 | Arc-Force selector | | |
| 28 | Stop control | G1 | Fuel level transmitter | | |
| 29 | Engine protection cover | H2 | Voltage commutator | | |
| 30 | Engine cooling/alternator fan belt | H6 | Fuel electro pump | | |
| 31 | Oil drain tap | H8 | Engine control unit EP7 | | |
| 31A | Hydraulic oil drain tap | I2 | 48V A.C. socket | | |
| 31B | Water drain tap | I3 | Welding scale switch | | |
| 31C | Exhaust tap for tank fuel | I4 | Preheating indicator | | |
| 32 | Button | I5 | Y/▲ switch | | |
| 33 | Start button | I6 | Start Local/Remote selector | | |
| 34 | Booster socket 12V | I8 | AUTOIDLE switch | | |
| 34A | Booster socket 24V | L | A.C. output indicator | | |
| 35 | Battery charge fuse | L5 | Emergency button | | |
| 36 | Space for remote control | L6 | Choke button | | |
| 37 | Remote control | M | Hour counter | | |
| 42 | Space for E.A.S. | M1 | Warning level light | | |
| 42A | Space for PAC | M2 | Contactora | | |
| 47 | Fuel pump | M5 | Engine control unit EP5 | | |
| 49 | Electric start socket | M6 | CC/CV switch | | |
| 54 | Reset button PTO HI | N | Voltmeter | | |
| 55 | Quick coupling m. PTO HI | N1 | Battery charge warning light | | |
| 55A | Quick coupling f. PTO HI | N2 | Thermal-magnetic circuit breaker/ Ground fault interrupter | | |
| 56 | Hydraulic oil filter | | | | |
| 59 | Battery charger thermal switch | N5 | Pre-heat push-button | | |
| 59A | Engine thermal switch | N6 | Connector - wire feeder | | |
| 59B | Aux current thermal switch | O1 | Oil pressure warning light/Oil alert | | |
| 59C | Supply thermal switch wire feeder-42V | P | Welding arc regulator | | |
| 59D | Pre-heater (spark plug) thermal switch | P8 | Water in fuel | | |
| 59E | Supply thermal switch oil/water heater | Q1 | Starter key | | |
| 59F | Electropump thermal switch | Q3 | Derivation box | | |
| 63 | No load voltage control | Q4 | Battery charge sockets | | |
| 66 | Choke control | Q7 | Welding selector mode | | |
| 67A | Auxiliary / welding current control | R3 | Siren | | |
| 68 | Cellulosic electrodes control | S | Welding ammeter | | |
| 69A | Voltmeter relay | S1 | Battery | | |
| 70 | Warning lights | S3 | Engine control unit EP4 | | |
| 71 | Selecting knob | S6 | Wire feeder supply switch | | |
| 72 | Load commut. push button | S7 | Plug 230V singlephase | | |
| 73 | Starting push button | T | Welding current regulator | | |
| 74 | Operating mode selector | T4 | Dirty air filter warning light/indicator | | |
| 75 | Power on warning light | T5 | Earth leakage relay | | |
| 76 | Display | T7 | Analogic instrument V/Hz | | |
| 79 | Wire connection unit | U | Current transformer | | |
| 86 | Selector | U3 | R.P.M. adjuster | | |
| 86A | Setting confirmation | U4 | Polarity inverter remote control | | |
| 87 | Fuel valve | U5 | Release coil | | |
| 88 | Oil syringe | U7 | Engine control unit EP6 | | |
| A3 | Insulation monitoring | V | Welding voltage voltmeter | | |
| A4 | Button indicating light 30 l/1' PTO HI | V4 | Polarity inverter control | | |
| B2 | Engine control unit EP2 | V5 | Oil pressure indicator | | |
| B3 | E.A.S. connector | W1 | Remote control switch | | |
| | | W3 | Selection push button 30 l/1' PTO HI | | |

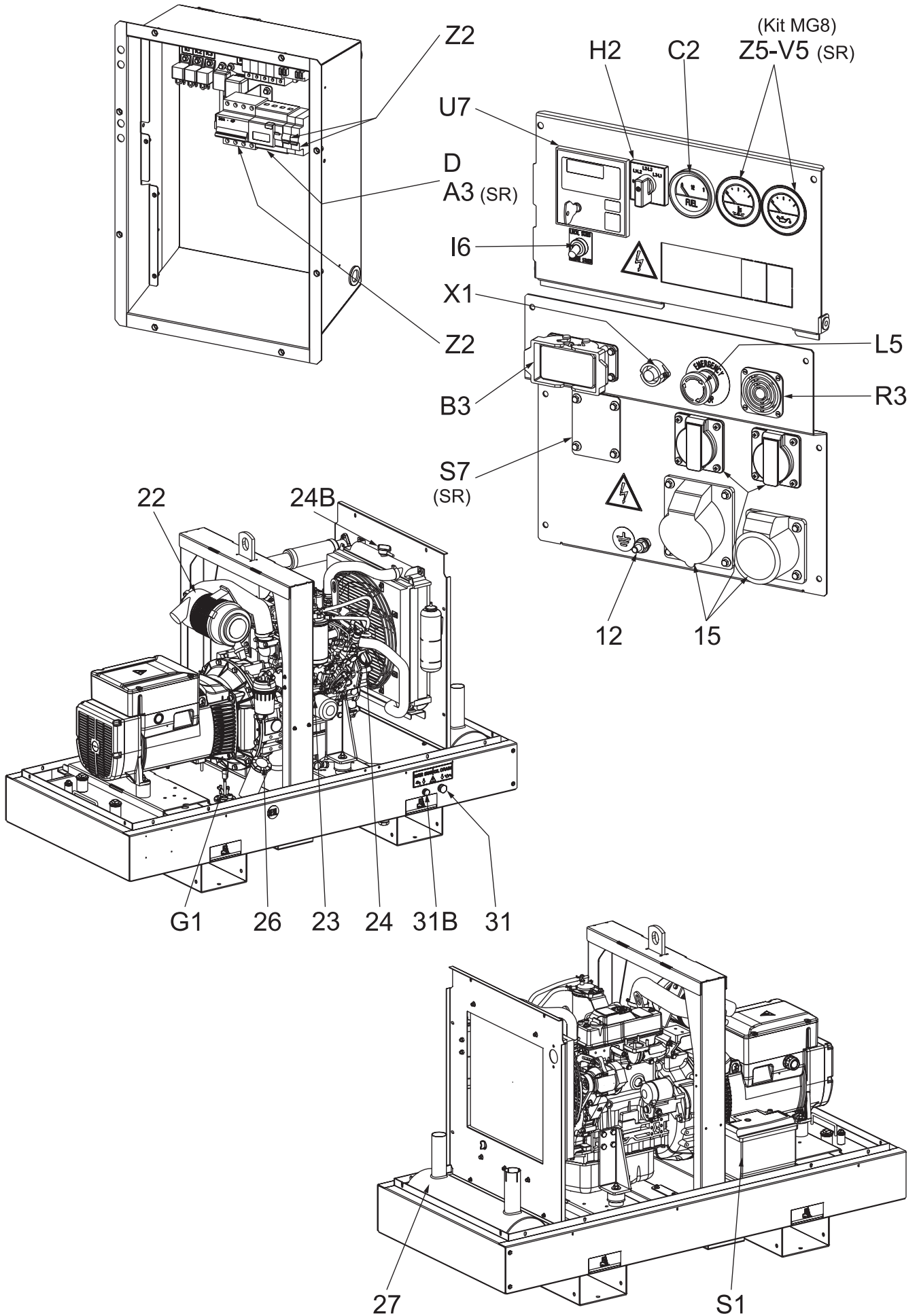

| | | |
|---------|---|--|
| Z2 | Thermal-magnetic circuit breaker | General switch for the gen-set. It protects both gen-set and related electrical circuit from over current /short circuit. |
| D | Ground fault interrupter (30 mA) | Device for protection against not-direct contacts for TN and TT systems (neutral grounded to frame) |
| 2xZ2 | Thermal-magnetic circuit breaker for single-phase sockets | Protects against short-circuits and overcurrents of electrical plants powered by single-phase sockets. |
| V5 (SR) | Oil pressure indicator | Indicates engine oil pressure (bar). |
| Z5 (SR) | Water temperature indicator | Indicates cooling liquid temperature (C). |
| C2 | Fuel level gauge | Indicates fuel in the reservoir (%). |
| H2 | Voltage commutator | Selection of visualized line voltage. |
| U7 | Engine control unit EP6 | Engine control unit. Genset stop/ start. Handling of generator alarms. display of alarms, Voltage, Hz, hour counter, Amps, battery voltage, operation messages. |
| 15 | A.C. socket | AUX sockets for load connection. |
| I6 | Start Local/Remote selector | Selection of engine control in use. Local start: control on board, EP6 operated. Remote start: external control, EAS operated. |
| 12 | Earth terminal | Ground connection point for gen-set. |
| X1 | Remote control socket | Connection for TCM35 remote control or for a NO clean contact, both operating only if EP6 is set to AUTO. |
| B3 | E.A.S. connector | Connection for automatic intervention unit (AMF + ATS). 10 pin connector. |
| L5 | Emergency button | To be pushed in case of danger. Immediate stop of the gen-set. |
| R3 | Siren | Gen-set acoustic alarm. |
| S7 (SR) | Plug 230V single-phase | External supply for engine heater (mains). |
| A3 (SR) | Insulation monitoring | Residual current monitor (RCM) - Protection device against indirect contact for IT systems (GE neutral not to ground). It opens the general circuit breaker when the isolation resistance falls below the selected threshold, thereby interrupting the power supply to the electrical system. The generator does not stop. The regulations on the RCM must be performed by qualified personnel. |

FRONT PANEL

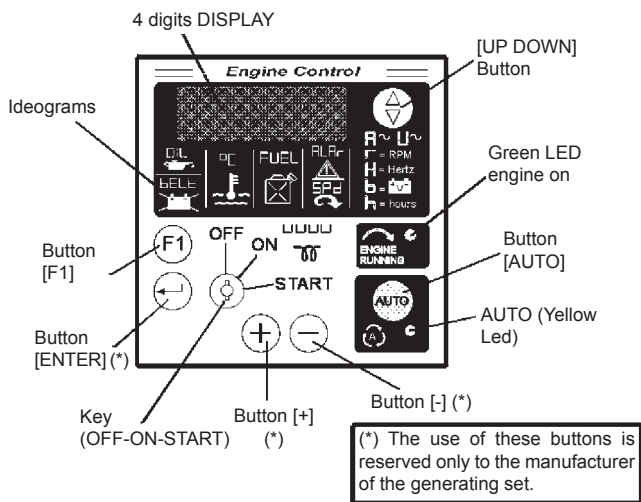

1.0 INTRODUCTION

The EP6 features Engine and Generating Set control and monitoring. The EP6 provides visual indication by means of LEDs (solid state lamps) and a Display (see section 10.0). It features OFF, MAN and AUTO operating modes. The display gives Messages for alarms and Measurement indications.

EP6 has programmable parameters. Please contact the producer of the generating set to receive instructions related to programming.

2.0 OPERATING MODE selection

The EP6 features AUTO (section 2.1), MANUAL (section 2.2) and OFF (section 2.3) operating modes. When the power supply is switched on, the EP6 behaves as follow:

- A) if the KEY-SWITCH is in the **OFF position**, the EP6 enters the OFF operating mode.
- B) if the KEY-SWITCH is in the **ON position**, the EP6 enters the AUTO operating mode. That is, if the EP6 was in AUTO prior to the supply removal. If not, the EP6 enters the MANUAL operating mode.

2.1 AUTO operating mode

To enter the "AUTO" operating mode use the following instructions:

- A) - Turn ON the key switch: the Display and LEDs illuminate for 1 second.
- B) - Wait for the end of the LAMP test, then push the AUTO pushbutton after the [UUUU] (Pre-glow) or [Sta-] (Start prompt) has been displayed. After this, the yellow Led AUTO will illuminate. If the REMOTE START input is not operative, the LED will flash. If operative, the LED illuminates continuously and a start cycle will take place (**NOTE**: the EP6 shuts down the display during the crank).

- C) - In order to cancel the AUTO operating mode, push the AUTO pushbutton (the yellow Led will turn OFF) or turn the KEY-SWITCH to OFF. Once in AUTO, the EP6 waits for a REMOTE START activation (see section 7.0). In case of an Automatic Periodic Test (A.P.T.), the display will show the message [tEst].

2.2 MANUAL operating mode

To start the engine follow the instructions:

- A) - Turn ON the KEY-SWITCH; the EP6 illuminates the LEDs and Display.
- B) - If the display shows the message [uuuu], the EP6 is counting the PRE-GLOW time; wait until the message disappears.
- C) - After the display shows the flashing message [StA-] (**NOTE**), turn the Key to START position (momentary position with spring-loaded return) until the engine starts. The message [. . .] indicates a MANUAL start.
- D) - To stop the engine, turn the KEY SWITCH to OFF.

NOTE: EP6 shows the blinking [StA-] message for 20 seconds. After this time, if the engine does not start, the EP6 displays the message [FAIL] (Fail to start, see section 4.07). To clear the alarm, turn the KEY-SWITCH to OFF.

2.3 OFF operating mode

This function is obtained by turning the KEY SWITCH to OFF. The OFF operating mode clears the fault alarms and shuts down the Display after 5 seconds. A blinking dot indicates the presence of the power supply. Press one of the pushbuttons to energize the display. In OFF operating mode, the EP6 allows reading of the parameters (see section 6.0).

3.0 DISPLAY features

The EP6 features a 4 Digit Display (section 10.0) to show measurements, settings and error messages. The [UP-DOWN] pushbutton selects one of the following menus:

- [AXXX] (*) Generator Current measurement
- [UXXX] The Voltage of the Generating Set
- [rPM] [XXXX] Speed of the engine
- [HXX.X] Frequency of the Generator
- [bXX.X] Battery Voltage
- [cXX.X] Charger Alternator Voltage
- [h] [XXXX] HOUR METER (the message [h] appears for a moment, and then, the counter will be displayed continuously).

(*): the symbol "X" means a numerical field.

4.0 ALARM messages

The alarms are displayed by means of messages. In case of alarm consult your Generating Set manufacturer. To remove the message, turn OFF the KEY-SWITCH. The EP6 may show one of the following:

| | |
|------------|---------------------------|
| [OIL] | Low Oil Pressure |
| [°C] | High Temperature |
| [O.SPd.] | Over Speed of the engine |
| [U.SPd] | Under Speed of the engine |
| [bELt] | Failure of the belt |
| [ALAR] | External Emergency Stop |
| [FUEL](1) | Low Fuel in the tank |
| [FAIL] | Starting Failure Alarm |
| [E 04] | Alternator Failure |
| [E 05](2) | Generator Overload |
| [Hi H](2) | Generator Over Frequency |
| [Lo H](2) | Generator Under Frequency |
| [Hi U] (2) | Generator Under Voltage |
| [Lo U](2) | Generator Under Voltage |
| [XX.X] | Battery Voltage |
| [Err] | Memory error |

(1) **[FUEL]** This message indicates Low Fuel in the tank . The engine stops if the contacts remain closed for 5 minutes continuously.

(2) To determine the value that caused the failure, push the [F1] pushbutton.

4.1 OPERATING messages

EP6 features messages to inform you about the following:

- [uuuu] Glow-plugs timing
- [U—] Voltage out of range
- [StA-] Start prompt
- [. . .] Starting by key switch
- [rEst] Rest timing
- [tEst] Automatic Test
- [CAL] Calibration
- [ProG] Programming
- [StOP] Stopping cycle

5.0 LEDs for visual indication

The EP6 features two LEDs (**see section 10.0**) to indicate the following conditions:

[ENGINE RUNNING]: this green led illuminates when the engine is running.

[AUTO]: this yellow LED blinks to indicate a standby mode. The EP6 monitors the REMOTE CONTROL and expects a command. The LED illuminates continuously when the REMOTE START is activated.

5.1 LEDs and Display Test

A test of the LEDs and DISPLAY is obtained automatically anytime the key switch is turned ON. The LEDs and DISPLAY light up for about 1 second.

6.0 Parameters and settings

The unit is programmed by the supplier of the Generating Set. Contact the Generator manufacturer in order to have the permission to program the module. It is possible to read the status of the internal programming at anytime. Follow the instructions:

- A) - Turn the Key in OFF (if the display indicates [STOP], wait until it disappears)
- B) - Push the pushbutton [F1] the display will show the first programmable parameter **[P.0]**.
- C) - Push the pushbutton [F1] the display will indicate the value of the parameter ([1"]).
- D) - Push the pushbutton [UP-DOWN] to select a parameter. Push [F1] to display the setting.
- E) - The display returns to menu mode if you have not used the pushbuttons for 2 minutes.

The list of the parameters follows (['] means minutes and ["] means seconds). Some parameters may differ according to the programming done by the genset manufacturer.

| Display | Parameter [Default] |
|---------|---|
| [P.0] | Remote Start Delay Timing (Input #7) [1"] Range: 1-59 secs or 1-15 mins Seconds or minutes of continuous REMOTE START command to initiate the automatic engine start (see section 7.0 and [P20] in this section). |
| [P.1] | Remote Stop Delay Timing (Input #7) [1"] Range: 1-59 secs or 1-15 mins Seconds or minutes of continuous absence of the REMOTE START command to initiate the stop cycle (see section 7.0 and [P.20] in this section). |
| [P.2] | Crank Timing (Output #10) [5"] Range:1-20 seconds Maximum insertion time of the <i>Starter Motor</i> . |
| [P.3] | Engine Running Trigger (Input #1) [8.0] Range: 3V-24V, [inh.]. If the voltage of the Charger Alternator rises above the [setting], the <i>Starter Motor</i> is disconnected. |
| [P.4] | Rest Timing [3"] Range: 3-20 secs. Time interval between starting attempts |
| [P. 5] | Starting Attempts [3] Range: 1-10 This parameter sets the number of attempts in the automatic start cycle |
| [P.6] | Generator UnderVoltage, short-circuit [inh.] Range: 80-400V. If the voltage drops under the [setting] for at least 6 secs, or under [setting]-20% for 1 sec, the Under-Voltage protection [Lo U] will shut down the engine. |
| [P.7] | Generator Over-Voltage [500V] Range: 110-550V or [inh.]. If the Generator voltage rises above the [setting] for at least 2 seconds, the EP6 will energize the over voltage protection [Hi U] (see section 4.0) to stop the engine. The [inh.] code inhibits the over voltage. |
| [P.8] | Generator Under-Frequency [Inh.] [inh.] 1 to 99Hz ([inh.]=disables the under frequency) This protection is delayed by about 6 seconds. The EP6 shuts down the engine and the display will show the [Lo H] message. |
| [P.9] | Generator Over-Frequency [55] 45 Hz to [inh.] ([inh.] disables the over frequency) This protection is delayed by about 2 seconds. The EP6 shuts down the engine and displays [Hi H] |
| [P.10] | Current Transformer Size [...] The range is 10/5 up to 1000/5 |
| [P.11] | Generator Overload Setting [inh.] Range: [inh.] to 1000 AThe EP6 shuts down the engine after a delay of 6 secs and shows the message [E05]. |
| [P.12] | Generator Failure Alarm [OFF] selection: [on] or [OFF].The code [on] enables the <i>Generator</i> failure alarm. The EP6 shows the [E04] message and the engine will shut down. |
| [P.13] | Glow Plugs/Choke Control (Output #11) [5"] Range: 1 to 99 secs.The EP6 energizes the output #11 for the programmed time. |
| [P.14] | Output Control [0] The following options are available: [0] None - [1] Choke Control - [2] Glow Plugs Control - [3] Choke Control |
| [P.15] | Belt Break Control [ON] Selection: [on] or [OFF]. The Belt Break alarm is indicated by means of the message [bELt] |
| [P.16] | Stop Solenoid Timing [2"] Range: 2-99 secs. Duration of the Stop cycle. |

- [P.17] Alarm Output Timing [1']**
[inh.] 1-59 secs 1-15 mins and [cont]. Time-out of the alarm output. The code [cont] disables the time-out, and the alarm remains energized until the OFF operating mode is selected. The [inh.] mode enables the use of the external contactor
- [P.18] Temperature Switch [n.o.]**
Selection: [n.o.] or [n.c.]
[n.o.] the engine shuts down if the contact closes
[n.c.] the engine shuts down if the contact opens
- [P.19] ALARM Control [n.c.]**
Selection: [n.o.] or [n.c.]
[n.o.] the engine shuts down if the contact closes
[n.c.] the engine shuts down if the contact opens
- [P.20] Remote Start [n.o.]**
Selection: [n.o.] or [n.c.]
[n.o.] the engine starts if the contact closes
[n.c.] the engine starts if the contact opens
- [P.21] Under Speed setting [1200]**
[Inh.] or 100-4000 r.p.m. The [Inh.] code disables the Under Speed shut down.
- [P.22] Over Speed setting [1700]**
100-4000 rpm or [Inh.]. The EP6 provides one second bypass delay. The [Inh.] code (>4000 r.p.m.) disables the Over Speed shut down.
- [P.23] Number of Teeth of the Flywheel [Inh.]**
[Inh.] or 1-500 teeth.
The [Inh.] code disables the reading of the Speed (section 3.0), the Over/Under Speed alarms, and the Crank termination (see [P.24]).
- [P.24] Crank OFF [Inh.]**
Crank Termination setting: 100-800 rpm
If the speed rises above the setting, the EP6 terminates the crank cycle. One second delay avoids false termination. The code [Inh.] inhibits the crank termination
- [P.25] Low Oil Pressure Alarm By-Pass [6"]**
Range: 0-99 secs. By-Pass Delay to ignore the Oil Pressure (input #3) during the engine starting cycle. This input requires normally closed contact
- [P.26] Automatic Periodic Test Cycle [inh.]**
Range: [inh.], 1-99 days
This is the interval time between the automatic periodic tests of the engine. The code [inh.] disables the Automatic Periodic Test (see section 19.0)
- [P.27] Automatic Engine Test Duration [10']**
Range: 1-99 minutes.
This is the duration of the automatic engine test.
- [P.28] Generator warm-up timing [20"]**
Range [inh.] 1-59 secs or 1-15 mins ([inh.]=No warm-up)
Active only when [P17]= [inh.] and the ALARM output is used to drive the contactor
- [P.29] Generator cooling timing [30"]**
Range [inh.] 1-59 secs or 1-15 mins ([inh.]=No cooling)
Active only when [P28]= [inh.] and the ALARM output is used to drive the GEN-SET contactor
- [P.30] N° poles of the alternator [...]**
Range [inh.] - [2] = 2 pole alternator - [4] = 4 pole alternator
- [P.31] Engine shut-down delay for low fuel [5']**
Range [inh.] = provides only optical - acoustical warning - 1 - 99 min.

7.0 REMOTE START

The EP6 features REMOTE START only in AUTO operating mode.

To operate the REMOTE START, follow the instructions.

- A) - Turn the KEY-SWITCH to the ON position; the Display and LEDs illuminate for 1 sec.
- B) - Wait until the end of the LEDs test.
- C) - Push the AUTO pushbutton as soon as possible (otherwise, after 20 seconds the EP6 enters the STARTING FAILURE); the [AUTO] yellow LED will illuminate as described in the section 4.

REMOTE START SWITCH:

If the REMOTE START input is activated, the [AUTO] yellow LED illuminates continuously and the display will indicate the count down of the internal **start delay** timer. The engine will start after the programmed **start delay** time. If the REMOTE START is deactivated, the EP6 drives the **stop delay time**. The display will indicate the count down and the [AUTO] yellow LED will flash. The engine will stop after the programmed **stop delay** time.

The EP6 will start the engine after the programmed number of days and the engine will run for the programmed time. To determine how the Automatic Periodic Test is programmed enter the Reading Mode (section 6.0 parameter [P.26] and [P.27]).

IMPORTANT NOTES

If the supply (battery voltage) is removed, the EP6 loses the counts and timings. If the supply restores, the EP6 starts to count the A.P.T. according to the programmed parameters [P.26] and [P.27]. It is important to synchronize the power on sequence with the desired Automatic Periodic Test.

8.0 SAFETY



NOTE

High voltage is present inside the EP6. To avoid electric-shock hazard, operating personnel must not remove the protective cover. Do not disconnect the grounding connection. Any interruption of the grounding connection can create an electric shock hazard. Before making external connections, always ground the PANEL first by connecting the control panel to ground.

9.0 Automatic periodic TEST

The EP6 does not use a clock to count the programmed days ([P.26] setting, section 6.0). The maximum error and drift of the counter is +/-0,5%. The user may experiment with shifting the periodic tests. To avoid error accumulation, and in case your unit is programmed to allow Automatic Periodic Test, we recommend the following procedures.

- disconnect the power supply of the EP6 (consult your genset supplier)
- wait for the desired start time (external clock reference)
- apply the power supply to the EP6 (consult your genset supplier)
- select the "AUTO" operating mode



WARNING

It is absolutely forbidden to connect the unit to the public mains and/or another electrical power source .



Access forbidden to area adjacent to electricity-generating group for all non-authorized personnel.



WARNING

For the canopy generator sets provided with doors, the following instruction shall be observed. During the normal operation, the doors of the engine compartment and/or the electrical box shall be kept closed, locked up if possible, as they must be considered in all respects as protection barriers. The access to the internal parts shall occur for maintenance purposes only, by qualified personnel and, in any case, when the engine is stopped.

The electricity-generating groups are to be considered electrical energy producing stations.

The dangers of electrical energy must be considered together with those related to the presence of chemical substances (fuels, oils, etc.), rotating parts and waste products (fumes, discharge gases, heat, etc.).

GENERATION IN AC (ALTERNATING CURRENT)

Before each work session check the efficiency of the ground connection for the electricity-generating group if the distribution system adopted requires it, such as, for example, the TT and TN systems.

Check that the electrical specifications for the units to be powered - voltage, power, frequency - are compatible with those of the generator. Values that are too high or too low for voltage and frequency can damage electrical equipment irreparably.

In some cases, for the powering of three-phase loads, it is necessary to ensure that the cyclic direction of the phases corresponds to the installation's requirements.

Connect the electric devices to be powered to the AC sockets, using suitable plugs and cables in prime condition.

Before starting up the group, make certain no dangerous situations exist on the installation to be powered.

Check that the thermal-magnetic switch (Z2) is in the OFF position (input lever in downward position).

Start up the electricity-generating group, positioning the thermal-magnetic switch (Z2) and differential switch (D) to ON (input lever in upward position).

Before powering on the utilities, check that the voltmeter (N) and frequency meter (E2) indicate nominal values; in addition, check on the voltmeter change-over switch (H2) (where it is assembled) that the three line voltages

are the same.

In the absence of a load, the values for voltage and frequency can be greater than their nominal values. See sections on VOLTAGE and FREQUENCY.

OPERATING CONDITIONS

POWER

The electrical power expressed in kVA on an electricity-generating group is the available output power to the reference environmental conditions and nominal values for: voltage, frequency, power factors ($\cos \varphi$).

There are various types of power: PRIME POWER (PRP), STAND-BY POWER established by ISO 8528-1 and 3046/1 Norms, and their definitions are listed in the manual's TECHNICAL SPECIFICATIONS page.

During the use of the electricity-generating group **NEVER EXCEED** the power indications, paying careful attention when several loads are powered simultaneously.

VOLTAGE

GENERATORS WITH COMPOUND SETTING (THREEPHASE)

GENERATORS WITH CONDENSER SETTING (SINGLEPHASE)

In these types of generators, the no-load voltage is generally greater than 3–5% with respect to its nominal value; f.e. for nominal voltage, threephase 400Vac or singlephase 230Vac, the no-load voltage can be comprised between 410-420V (threephase) and 235-245V (singlephase). The precision of the load voltage is maintained within $\pm 5\%$ with balanced loads and with a rotation speed variation of 4%. Particularly, with resistive loads ($\cos \varphi = 1$), a voltage over-elevation occurs which, with the machine cold and at full load, can even attain +10 %, a value which in any case is halved after the first 10-15 minutes of operation.

The insertion and release of the full load, under constant rotation speed, provokes a transitory voltage variation that is less than 10%; the voltage returns to its nominal value within 0.1 seconds.

GENERATORS WITH ELECTRONIC SETTING (A.V.R.)

In these types of generators, the voltage precision is maintained within $\pm 1,5\%$, with speed variations comprised from -10% to +30%, and with balanced loads. The voltage is the same both with no-load and with load; the insertion and release of the full load provokes a transitory voltage variation that is less than 15%; the voltage returns to its nominal value within 0.2–0.3 seconds.

FREQUENCY

The frequency is a parameter that is directly dependent on the motor's rotation speed. Depending on the type of alternator, 2 or 4 pole, we will have a frequency of 50/60 Hz with a rotation speed of 3000/3600 or 1500/1800 revolutions per minute.



The frequency, and therefore the number of motor revolutions, is maintained constant by the motor's speed regulation system.

Generally, this regulator is of a mechanical type and presents a droop from no-load to nominal load which is less than 5 % (static or droop), while under static conditions precision is maintained within $\pm 1\%$. Therefore, for generators at 50Hz the no-load frequency can be 52–52.5 Hz, while for generators at 60Hz the no-load frequency can be 62.5–63Hz.

In some motors or for special requirements the speed regulator is electronic; in these cases, precision under static operating conditions attains $\pm 0.25\%$, and the frequency is maintained constant in operation from no-load to load (isochronal operation).

POWER FACTOR - $\cos \varphi$

The power factor is a value which depends on the load's electrical specifications; it indicates the ratio between the Active Power (kW) and Apparent Power (kVA). The apparent power is the total power necessary for the load, achieved from the sum of the active power supplied by the motor (after the alternator has transformed the mechanical power into electrical power), and the Reactive Power (kVAR) supplied by the alternator. The nominal value for the power factor is $\cos \varphi = 0,8$; for different values comprised between 0.8 and 1 it is important during usage not to exceed the declared active power (kW), so as to not overload the electricity-generating group motor; the apparent power (kVA) will diminish proportionally to the increase of $\cos \varphi$.

For $\cos \varphi$ values of less than 0.8 the alternator must be downgraded, since at equal apparent power the alternator should supply a greater reactive power. For reduction coefficients, contact the Technical Service Department.

START-UP OF ASYNCHRONOUS MOTORS

The start-up of asynchronous motors from an electricity-generating group can prove critical because of high start-up currents the asynchronous motor requires (I start-up = up to 8 times the nominal current I_n). The start-up current must not exceed the alternator's admissible overload current for brief periods, generally in the order of 250–300% for 10–15 seconds.

To avoid a group oversize, we recommend following these precautionary measures:

- in the case of a start-up of several motors, subdivide the motors into groups and set up their start-up at intervals of 30–60 seconds.
- when the operating machine coupled to the motor allows it, see to a start-up with reduced voltage, star point/triangle start-up or with autotransformer, or use a soft-start system.

In all cases, when the user circuit requires the start-up of an asynchronous motor, it is necessary to check that there are no utilities inserted into the installation, which in the case of a voltage droop can cause more or less serious disservices (opening of contact points, temporary lack of power to control and command systems, etc.).

SINGLE-PHASE LOADS

Power to monophasic utilities by means of three-phase generators requires some operating limitations.

- In single-phase operation, the declared voltage tolerance can no longer be maintained by the regulator (compound or electronic regulator), since the system becomes highly unbalanced. **The voltage variation on the phases not affected by the power can prove dangerous; we recommend sectioning the other loads eventually connected.**
- The maximum power which can be drawn between Neutral and Phase (start connection) is generally 1/3 of the nominal three-phase power; some types of alternators even allow for 40%. Between two Phases (triangle connection) the maximum power cannot exceed 2/3 of the declared three-phase power.
- In electricity-generating groups equipped with monophasic sockets, use these sockets for connecting the loads. In other cases, always use the "R" phase and Neutral.

ELECTRIC PROTECTIONS

THERMAL-MAGNETIC SWITCH

The electricity-generating group is protected against short-circuits and against overloads by a thermal-magnetic switch (Z2) situated upstream from the installation. Operating currents, both thermic and magnetic, can be fixed or adjustable in relation to the switch model.

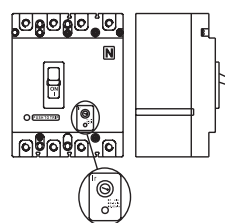

In models with adjustable operating current **do not modify** the settings, since doing so can compromise the installation's protection or the electricity-generating group's output characteristics. For eventual variations, contact our Technical Service Department.

The intervention of the protection feature against overloads is not instantaneous, but follows a current overload/time outline; the greater the overload

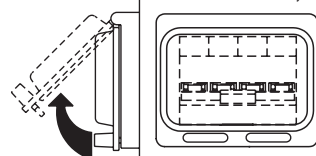

the less the intervention. Furthermore, keep in mind that the nominal operating current refers to an operating temperature of 30°C, so that each variation of 10°C

roughly corresponds to a variation of 5% on the value of nominal current.

In case of an intervention on the part of the thermal magnetic protection device, check that the total absorption does not exceed the electricity-generating group's nominal current.



DIFFERENTIAL SWITCH

The differential switch or differential relay guarantee protection against indirect contacts due to malfunction currents towards the ground. When the device detects a malfunction current that is higher than the nominal current or the set current, it intervenes by cutting off power to the circuit connected.

In the case of an intervention

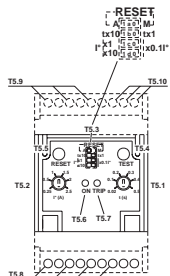
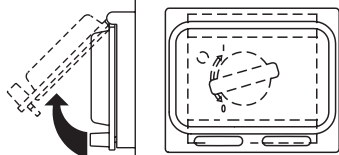

by the differential switch, check that there are no sheathing defects in the installation: connection cables, sockets and plugs, utilities connected.

Before each work session, check the operation of the differential protection device by pressing the test key. The electricity-generating group must be in operation, and the lever on the differential switch must be in the ON position.

THERMIC PROTECTION

Generally present to protect against overloads on an individual power socket c.a.

When the nominal operating current has been exceeded, the protection device intervenes by cutting off power to the socket.

The intervention of the protection device against overloads is not instantaneous, but follows a current overload/time outline; the greater the overload the less the intervention.

In case of an intervention, check that the current absorbed by the load does not exceed the protection's nominal operating current.

Allow the protection to cool off for a few minutes before resetting by pressing the central pole.



USAGE WITH EAS AUTOMATIC START-UP PANEL

The electricity-generating group in combination with the EAS automatic start-up panel forms a unit for distributing electrical energy within a few seconds of a power failure from the commercial electrical power line.

Below is some general operating information; refer to the automatic panel's specific manual for details on installation, command, control and signalling operations.

- Perform connections on the installation in safety conditions. Position the automatic panel in RESET or LOCKED mode.
- Carry out the first start-up in MANUAL mode. Check that the generator's LOCAL START / REMOTE START switch (I6) is in the REMOTE position. Check that the generator switches are enabled (input lever in upward position).

Position the EAS panel in manual mode by pressing MAN. key, and only after having checked that there are no dangerous situations, press the START key to start the electricity-generating group.

- During the operation of the generator, all controls and signals from both the automatic panel and group are enabled; it is therefore possible to control its operation from both positions.

In case of an alarm with a shutdown of the motor (low pressure, high temperature, etc.), the automatic panel will indicate the malfunction that has caused the stoppage, while the generator's front panel will be disabled and will no longer supply any information.

ATTENTION

Do not keep the central pole on the thermic protection forcefully pressed to prevent its intervention.





NOTE

Don not intervene on the setting of the protection switch. Before using the machine check the ON warning lamp lighting.

USE AS TROUBLE INDICATOR:

Placed on the front panel, the insulation monitor (A3) is a relay which controls continuously the insulation of the generation a.c. circuits towards the ground.

The device generates internally a continuous 12V voltage which is applied between the circuit under control and the ground.

USE AS TROUBLE INDICATOR AND INTERVENTION:

The insulation monitor controls a device (release coil, contactor, etc.) which opens the whole circuit, lifting voltage in the whole part of the machine a.c. generation.

USE OF RI – R22M MODEL:

- To vary the regulation call our Technical Assistance Department
- The LED ON shows that the device is fed.
- Check that it works correctly pressing the TEST push button
- The LED TRIP will simulate on intervention or anyway will show the real intervention in case the insulation fails.
- Reset the circuit pressing the RESET push button after having checked the plant and removed the problem cause.

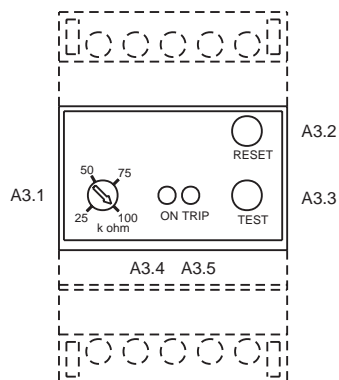

LEGEND:

- A3.1 - Adjustment potentiometer insulation resistance
- A3.2 - Manual reset push button
- A3.3 - Test push button
- A3.4 - Auxiliary feeding presence LED
- A3.5 - TRIP LED

USE OF SRI/D3 MODEL

- To vary the regulation call our Technical Assistance Department
- The warning light ON shows that the device is fed.-
- Pressing a long time the Test push-button, the Fault led lights and the Alarm led twinkles;
- Leaving it, the Alarm led goes off while the Fault led remains lit. The pressure on the Reset key brings the device back to initial conditions.
- If the insulation resistance goes down below the fixed alarm value, the Alarm led twinkles, at the same time the Alarm contact switches; if the insulation resistance goes down furtherly and becomes inferior to the fixed value for the Fault, the Fault led lights and at the same time both exchange contacts switch putting the Fault in activity and the Alarm at rest.
- After having checked the device and removed the cause of the problem, re-establish the circuit pressing the push-button RESET.

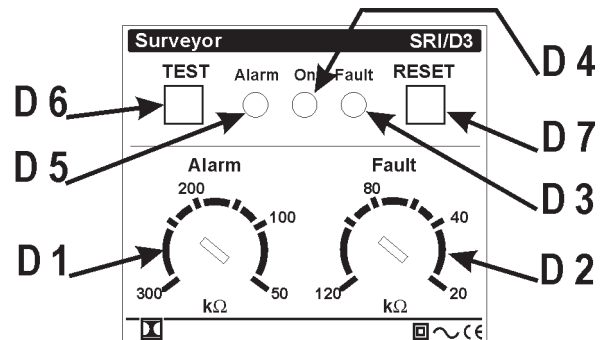

LEGEND:

- D1 Regulation of Alarm threshold
- D2 Regulation of Fault threshold
- D3 Led, fault indication
- D4 Led feeding indication
- D5 Led Alarm indication
- D6 Test push-button
- D7 Reset push-button



MAKE SURE

- The selector LOCAL START/REMOTE START (I6) of the generating set must be switched on LOCAL-START.
- Put the selector „switch board (N7)“ on ON.



The coupling of the TCM 35 with the generating set, ready for remot starting, permits to work far from the set itself.

The remote control is connected to the front plate (X1), and/or rear plate, with a multiple connector.

N.B. The remote control TCM 35 can be used only with machines equipped with control and protection device EP6 (U7).

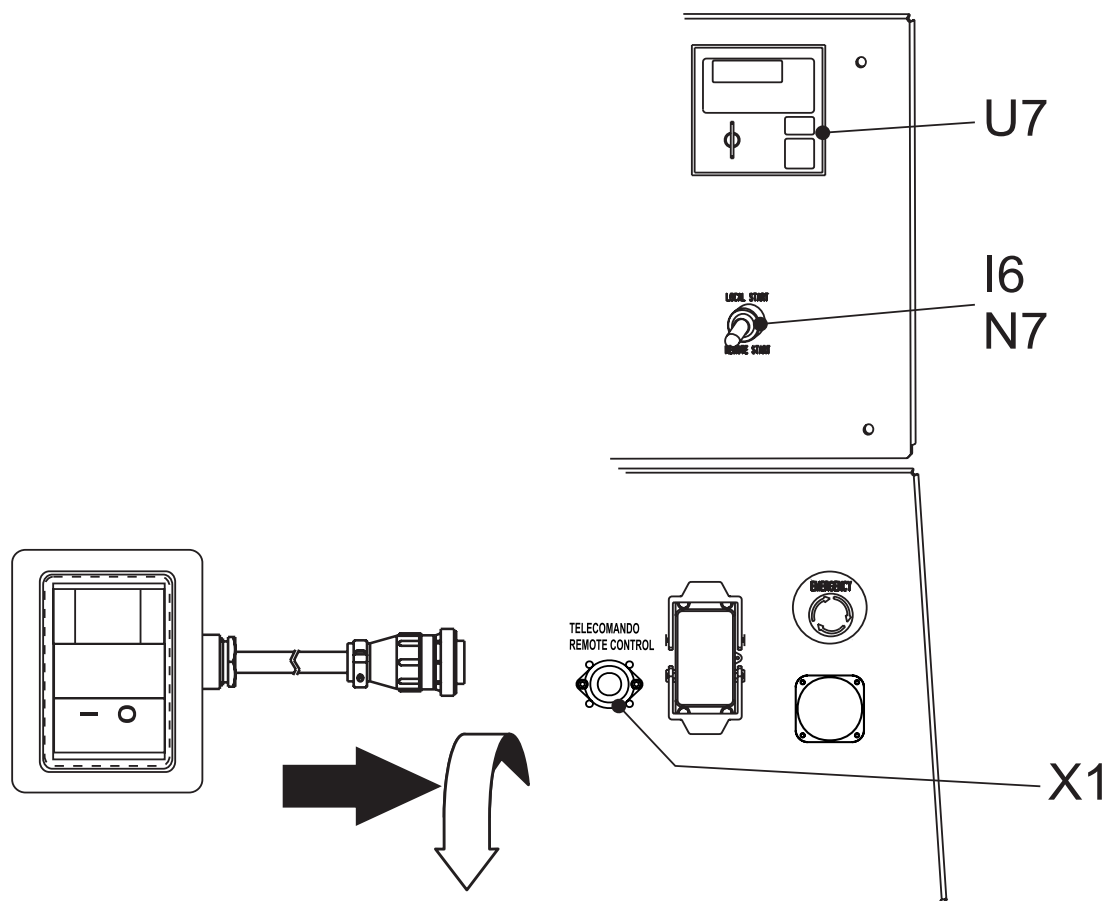
For use of TCM 35 see page M21 (start and stop) of this manual.



|  WARNING | | |
|--|---|---|
|  | <ul style="list-style-type: none"> • Have qualified personnel do maintenance and troubleshooting work. • Stop the engine before doing any work inside the machine. If for any reason the machine must be operated while working inside, pay attention moving parts, hot parts (exhaust manifold and muffler, etc.) electrical parts which may be unprotected when the machine is open. • Remove guards only when necessary to perform maintenance, and replace them when the maintenance requiring their removal is complete. • Use suitable tools and clothes. • Do not modify the components if not authorized. <p>- See pag. M1.1 -</p> |  |
| MOVING PARTS can injure | | HOT surface can hurt you |

NOTE

By maintenance at care of the utilizer we intend all the operatios concerning the verification of mechanical parts, electrical parts and of the fluids subject to use or consumption during the normal operation of the machine.

For what concerns the fluids we must consider as maintenance even the periodical change and or the refills eventually necessary.

Maintenance operations also include machine cleaning operations when carried out on a periodic basis outside of the normal work cycle.

The repairs **cannot be considered** among the maintenance activities, i.e. the replacement of parts subject to occasional damages and the replacement of electric and mechanic components consumed in normal use, by the Assistance Authorized Center as well as by manufacturer.

The replacement of tires (for machines equipped with trolleys) must be considered as repair since it is not delivered as standard equipment any lifting system.

The periodic maintenance should be performed according to the schedule shown in the engine manual. An optional hour counter (M) is available to simplify the determination of the working hours.

maintenance intervals and specific checks for each model: it is necessary to consult the specific engine or alternator USER AND MAINTENANCE manual.

VENTILATION

Make certain there are no obstructions (rags, leaves or other) in the air inlet and outlet openings on the machine, alternator and motor.

ELECTRICAL PANELS

Check condition of cables and connections daily. Clean periodically using a vacuum cleaner, **DO NOT USE COMPRESSED AIR.**

DECALS AND LABELS

All warning and decals should be checked once a year and **replaced** if missing or unreadable.

STRENUOUS OPERATING CONDITIONS



Under extreme operating conditions (frequent stops and starts, dusty environment, cold weather, extended periods of no load operation, fuel with over 0.5% sulphur content) do maintenance more frequently.

BATTERY WITHOUT MAINTENANCE DO NOT OPEN THE BATTERY

The battery is charged automatically from the battery charger circuit supplied with the engine.

Check the state of the battery from the colour of the warning light which is in the upper part.

- Green colour: battery OK
- Black colour: battery to be recharged
- White colour: battery to be replaced

|  IMPORTANT |
|--|
| <div style="display: flex;"> <div style="flex: 1; text-align: center;"></div> <div style="flex: 2;"> <p>In the maintenance operations avoid that polluting substances, liquids, exhausted oils, etc. bring damage to people or things or can cause negative effects to surroundings, health or safety respecting completely the laws and/or dispositions in force in the place.</p> </div> </div> |

ENGINE and ALTERNATOR

PLEASE REFER TO THE SPECIFIC MANUALS PROVIDED.

Every engine and alternator manufacturer has



|  NOTE |
|---|
| <p>THE ENGINE PROTECTION NOT WORK WHEN THE OIL IS OF LOW QUALITY BECAUSE NOT CHARGED REGULARLY AT INTERVALS AS PRESCRIBED IN THE OWNER'S ENGINE MANUAL.</p> |



ATTENTION

- Maintenance operations on the electricity-generating group prearranged for automatic operation must be carried out with the panel in RESET mode.
- Maintenance operations on the installation's electrical panels must be carried out in complete safety by cutting off all external power sources: ELECTRICAL POWER, GROUP and BATTERY.

For the electricity-generating groups prearranged for automatic operation, in addition to carrying out all periodic maintenance operations foreseen for normal usage, various operations must be carried out that are necessary in relation to the specific type of use. The electricity-generating group in fact must be continuously prepared for operation, even after prolonged periods of inactivity.

MAINTENANCE GENERATING SET WITH AUTOMATIC BOARD

|  | EVERY WEEK | EVERY MONTH AND/OR AFTER INTERVENTION ON LOAD | EVERY YEAR |
|--|-------------------|--|-------------------|
| 1. TEST or AUTOMATIC TEST cycle to keep the generating set constantly operative | NO-LOAD X | WITH LOAD X | |
| 2. Check all levels: engine oil, fuel level, battery electrolyte., if necessary top it up. | X | X | |
| 3. Control of electrical connections and cleaning of control panel | | X | X |

- **Carry out motor oil change at least once a year, even if the requested number of hours has not been attained.**

| <i>Problem</i> | <i>Possible cause</i> | <i>Solution</i> |
|--|---|--|
| ENGINE | | |
| The motor does not start up | <ol style="list-style-type: none"> 1) Start-up switch (I6) (where it is assembled) in incorrect position 2) Emergency button (L5) pressed 3) Preheating (where it is assembled) 4) Engine control unit or starting key faulty. 5) Battery low 6) Battery cable terminals loose or corroded 7) Start-up motor defective 8) No fuel or air in feed circuit 9) Malfunction on feed circuit: defective pump, injector blocked, etc. 10) Air filter or fuel filter clogged 11) Air in the gasoil filter. 12) Motor stopping device defective 13) Malfunction on electrical power circuit on generator control panel | <ol style="list-style-type: none"> 1) Check position 2) Unblock 3) Lacking or insufficient preheating phase for sparkplugs. Malfunction in circuit: repair. 4) Replace 5) Recharge or replace. Check the battery charge circuit on motor and automatic panel. 6) Tighten and clean. Replace if corroded. 7) Repair or replace. 8) Refill tank, un-aerate the circuit. 9) Ask for intervention of Service Department. 10) Clean or replace 11) Take the air out filling the filter with gasoil. 12) Replace. 13) Check and repair. |
| The motor does not accelerate. Inconstant speed. | <ol style="list-style-type: none"> 1) Air filter or fuel filter clogged. 2) Malfunction on feed circuit: defective pump, injector blocked, etc. 3) Oil level too high. 4) Motor speed regulator defective. | <ol style="list-style-type: none"> 1) Clean or replace. 2) Ask for intervention of Service Department. 3) Eliminate excess oil. 4) Ask for intervention of Service Department |
| Black smoke | <ol style="list-style-type: none"> 1) Air filter clogged. 2) Overload. 3) Injectors defective. Injection pump requires calibration. | <ol style="list-style-type: none"> 1) Clean or replace 2) Check the load connected and diminish. 3) Ask for intervention of Service Department. |
| White smoke | <ol style="list-style-type: none"> 1) Oil level too high. 2) Motor cold or in prolonged operation with little or no load. 3) Segments and/or cylinders worn out. | <ol style="list-style-type: none"> 1) Eliminate excess oil. 2) Insert load only with motor sufficiently hot 3) Ask for intervention of Service Department. |
| Too little power provided by motor. | <ol style="list-style-type: none"> 1) Air filter clogged. 2) Insufficient fuel distribution, impurities or water in feed circuit. 3) Injectors dirty or defective. | <ol style="list-style-type: none"> 1) Clean or replace. 2) Check the feed circuit, clean and refill once again. 3) Ask for intervention of Service Department. |
| Low oil pressure | <ol style="list-style-type: none"> 1) Oil level insufficient 2) Air filter clogged. 3) Oil pump defective. 4) Alarm malfunction. | <ol style="list-style-type: none"> 1) Reset level. Check for leaks. 2) Replace filter. 3) Ask for intervention of Service Department. 4) Check the sensor and electrical circuit. |
| High temperature | <ol style="list-style-type: none"> 1) Overload 2) Insufficient ventilation. 3) Insufficient coolant liquid (Only for water cooled motors) 4) Water radiator or oil clogged (where it is assembled) 5) Water circulating pump defective (Only for water cooled motors) 6) Injectors defective. Injection pump requires calibration 7) Alarm malfunction | <ol style="list-style-type: none"> 1) Check the load connected and diminish. 2) Check the cooling vent and relative transmission belts 3) Restore level. Check for leaks or breakage in the entire cooling circuit, pipes, couplings, etc. 4) Clean cooling fins on radiator 5) Ask for intervention of Service Department 6) Ask for intervention of Service Department 7) Check the sensor and electrical circuit |

I

GB

Troubleshooting

F

Diesel engine

M

40.2.1

REV.4-03/11

| Problem | Possible cause | Solution |
|---|---|---|
| GENERATOR | | |
| Absence of output voltage | <ol style="list-style-type: none"> 1) Voltage switch in position 0 2) Voltage switch faulty 3) Protection tripped due to overload 4) Differential protection device tripped. (Differential switch, differential relay) 5) Protection devices defective 6) Alternator not sparked 7) Alternator defective | <ol style="list-style-type: none"> 1) Check position 2) Check connections and working of the switch, repair or replace 3) Check the load connected and diminish 4) Check on the entire installation: cables, connections, utilities connected have no defective sheathing which may cause incorrect currents to ground 5) Replace 6) Carry out external spark test as indicated in alternator manual. Ask for intervention of Service Department 7) Check winding, diodes, etc. on alternator (Refer to alternator manual) Repair or replace. Ask for intervention of Service Department |
| No-load voltage too low or too high | <ol style="list-style-type: none"> 1) Incorrect motor running speed 2) Voltage regulating device (where it is assembled) defective or requires calibration 3) Alternator defective | <ol style="list-style-type: none"> 1) Regulate speed to its nominal no-load value 2) Adjust regulator device as indicated in alternator manual, or replace. For generators with double voltage control AVR and COMPOUND, act on the excitation circuit as shown in the alternator manual. 3) Check winding, diodes, etc. on alternator (Refer to alternator manual) Repair or replace Ask for intervention of Service Department |
| Corrected no-load voltage too low with load | <ol style="list-style-type: none"> 1) Incorrect motor running speed due to overload 2) Load with $\cos \varphi$ less than 0.8 3) Alternator defective | <ol style="list-style-type: none"> 1) Check the load connected and diminish 2) Reduce or rephase load 3) Check winding, diodes, etc. on alternator (Refer to alternator manual) Repair or replace Ask for intervention of Service Department |
| Unstable tension | <ol style="list-style-type: none"> 1) Contacts malfunctioning 2) Irregular rotation of motor 3) Alternator defective | <ol style="list-style-type: none"> 1) Check electrical connections and tighten 2) Ask for intervention of Service Department 3) Check winding, diodes, etc. on alternator (Refer to alternator manual) Repair or replace Ask for intervention of Service Department |

In case the machine should not be used for more than 30 days, make sure that the room in which it is stored presents a suitable shelter from heat sources, weather changes or anything which can cause rust, corrosion or damages to the machine.

☞ Have **qualified** personnel prepare the machine for storage.

GASOLINE ENGINE

Start the engine: It will run until it stops due to the lack of fuel.

Drain the oil from the engine sump and fill it with new oil (see page M25).

Pour about 10 cc of oil into the spark plug hole and screw the spark plug, after having rotated the crankshaft several times.

Rotate the crankshaft slowly until you feel a certain compression, then leave it.

In case the battery, for the electric start, is assembled, disconnect it.

Clean the covers and all the other parts of the machine carefully.

Protect the machine with a plastic hood and store it in a dry place.

DIESEL ENGINE

For short periods of time it is advisable, about every 10 days, to make the machine work with load for 15-30 minutes, for a correct distribution of the lubricant, to recharge the battery and to prevent any possible blocking of the injection system.

For long periods of inactivity, turn to the after sales service of the engine manufacturer.

Clean the covers and all the other parts of the machine carefully.

Protect the machine with a plastic hood and store it in a dry place.

In case of necessity for first aid and of fire prevention, see page. M2.5.



IMPORTANT



In the storage operations avoid that polluting substances, liquids, exhausted oils, etc. bring damage to people or things or can cause negative effects to surroundings, health or safety respecting completely the laws and/or dispositions in force in the place.



☞ Have **qualified** personnel disassemble the machine and dispose of the parts, including the oil, fuel, etc., in a correct manner when it is to be taken out of service.

In case of necessity for first aid and fire prevention, see page M2.5.

As cust off we intend all operations to be made, at utilizer's care, at the end of the use of the machine. This comprises the dismantling of the machine, the subdivision of the several components for a further reutilization or for getting rid of them, the eventual packing and transportation of the eliminated parts up to their delivery to the store, or to the bureau entrusted to the cust off or to the storage office, etc.

The several operations concerning the cust off, involve the manipulation of fluids potentially dangerous such as: lubricating oil and battery electrolyte.

The dismantling of metallic parts liable to cause injuries or wounds, must be made wearing heavy gloves and using suitable tools.

The getting rid of the various components of the machine must be made accordingly to rules in force of law a/o local rules.



Particular attention must be paid when getting rid of:
lubricating oils, battery electrolyte, and inflammable liquids such as fuel, cooling liquid.

The machine user is responsible for the observance of the norms concerning the environment conditions with regard to the elimination of the machine being cust off and of all its components.

In case the machine should be cust off without any previous disassembly it is however compulsory to remove:

- tank fuel
- engine lubricating oil
- cooling liquid from the engine
- battery

NOTE: BCS is involved with custing off the machine **only** for the second hand ones, when not reparable. This, of course, after authorization.

| | |
|--|--|
|  IMPORTANT | |
|  | In the cust-off operations avoid that polluting substances, liquids, exhausted oils, etc. bring damage to people or things or can cause negative effects to surroundings, health or safety respecting completely the laws and/or dispositions in force in the place. |

| | | | | | |
|----|--|----|---------------------------------------|----|---|
| A | : Alternator | F3 | : Stop push-button | L6 | : Choke button |
| B | : Wire connection unit | G3 | : Ignition coil | M6 | : Switch CC/CV |
| C | : Capacitor | H3 | : Spark plug | N6 | : Connector – wire feeder |
| D | : G.F.I. | I3 | : Range switch | O6 | : 420V/110V 3-phase transformer |
| E | : Welding PCB transformer | L3 | : Oil shut-down button | P6 | : Switch IDLE/RUN |
| F | : Fuse | M3 | : Battery charge diode | Q6 | : Hz/V/A analogic instrument |
| G | : 400V 3-phase socket | N3 | : Relay | R6 | : EMC filter |
| H | : 230V 1phase socket | O3 | : Resistor | S6 | : Wire feeder supply switch |
| I | : 110V 1-phase socket | P3 | : Sparkler reactor | T6 | : Wire feeder socket |
| L | : Socket warning light | Q3 | : Output power unit | U6 | : DSP chopper PCB |
| M | : Hour-counter | R3 | : Electric siren | V6 | : Power chopper supply PCB |
| N | : Voltmeter | S3 | : E.P.4 engine protection | Z6 | : Switch and leds PCB |
| P | : Welding arc regulator | T3 | : Engine control PCB | W6 | : Hall sensor |
| Q | : 230V 3-phase socket | U3 | : R.P.M. electronic regulator | X6 | : Water heater indicator |
| R | : Welding control PCB | V3 | : PTO HI control PCB | Y6 | : Battery charge indicator |
| S | : Welding current ammeter | Z3 | : PTO HI 20 l/min push-button | A7 | : Transfer pump selector AUT-0-MAN |
| T | : Welding current regulator | W3 | : PTO HI 30 l/min push-button | B7 | : Fuel transfer pump |
| U | : Current transformer | X3 | : PTO HI reset push-button | C7 | : "GECO" generating set test |
| V | : Welding voltage voltmeter | Y3 | : PTO HI 20 l/min indicator | D7 | : Flooting with level switches |
| Z | : Welding sockets | A4 | : PTO HI 30 l/min indicator | E7 | : Voltmeter regulator |
| X | : Shunt | B4 | : PTO HI reset indicator | F7 | : WELD/AUX switch |
| W | : D.C. inductor | C4 | : PTO HI 20 l/min solenoid valve | G7 | : Reactor, 3-phase |
| Y | : Welding diode bridge | D4 | : PTO HI 30 l/min solenoid valve | H7 | : Switch disconnecter |
| A1 | : Arc striking resistor | E4 | : Hydraulic oil pressure switch | I7 | : Solenoid stop timer |
| B1 | : Arc striking circuit | F4 | : Hydraulic oil level gauge | L7 | : "VODIA" connector |
| C1 | : 110V D.C./48V D.C. diode bridge | G4 | : Preheating glow plugs | M7 | : "F" EDC4 connector |
| D1 | : E.P.1 engine protection | H4 | : Preheating gearbox | N7 | : OFF-ON-DIAGN. selector |
| E1 | : Engine stop solenoid | I4 | : Preheating indicator | O7 | : DIAGNOSTIC push-button |
| F1 | : Acceleration solenoid | L4 | : R.C. filter | P7 | : DIAGNOSTIC indicator |
| G1 | : Fuel level transmitter | M4 | : Heater with thermostat | Q7 | : Welding selector mode |
| H1 | : Oil or water thermostat | N4 | : Choke solenoid | R7 | : VRD load |
| I1 | : 48V D.C. socket | O4 | : Step relay | S7 | : 230V 1-phase plug |
| L1 | : Oil pressure switch | P4 | : Circuit breaker | T7 | : V/Hz analogic instrument |
| M1 | : Fuel warning light | Q4 | : Battery charge sockets | U7 | : Engine protection EP6 |
| N1 | : Battery charge warning light | R4 | : Sensor, cooling liquid temperature | V7 | : G.F.I. relay supply switch |
| O1 | : Oil pressure warning light | S4 | : Sensor, air filter clogging | Z7 | : Radio remote control receiver |
| P1 | : Fuse | T4 | : Warning light, air filter clogging | W7 | : Radio remote control transmitter |
| Q1 | : Starter key | U4 | : Polarity inverter remote control | X7 | : Isometer test push-button |
| R1 | : Starter motor | V4 | : Polarity inverter switch | Y7 | : Remote start socket |
| S1 | : Battery | Z4 | : Transformer 230/48V | A8 | : Transfer fuel pump control |
| T1 | : Battery charge alternator | W4 | : Diode bridge, polarity change | B8 | : Ammeter selector switch |
| U1 | : Battery charge voltage regulator | X4 | : Base current diode bridge | C8 | : 400V/230V/115V commutator |
| V1 | : Solenoid valve control PCB | Y4 | : PCB control unit, polarity inverter | D8 | : 50/60 Hz switch |
| Z1 | : Solenoid valve | A5 | : Base current switch | E8 | : Cold start advance with temp. switch |
| W1 | : Remote control switch | B5 | : Auxiliary push-button ON/OFF | F8 | : START/STOP switch |
| X1 | : Remote control and/or wire feeder socket | C5 | : Accelerator electronic control | G8 | : Polarity inverter two way switch |
| Y1 | : Remote control plug | D5 | : Actuator | H8 | : Engine protection EP7 |
| A2 | : Remote control welding regulator | E5 | : Pick-up | I8 | : AUTOIDLE switch |
| B2 | : E.P.2 engine protection | F5 | : Warning light, high temperature | L8 | : AUTOIDLE PCB |
| C2 | : Fuel level gauge | G5 | : Commutator auxiliary power | M8 | : A4E2 ECM engine PCB |
| D2 | : Ammeter | H5 | : 24V diode bridge | N8 | : Remote emergency stop connector |
| E2 | : Frequency meter | I5 | : Y/▲ commutator | O8 | : V/A digital instruments and led VRD PCB |
| F2 | : Battery charge transformer | L5 | : Emergency stop button | P8 | : Water in fuel |
| G2 | : Battery charge PCB | M5 | : Engine protection EP5 | Q8 | : Battery disconnect switch |
| H2 | : Voltage selector switch | N5 | : Pre-heat push-button | R8 | : Inverter |
| I2 | : 48V a.c. socket | O5 | : Accelerator solenoid PCB | S8 | : Overload led |
| L2 | : Thermal relay | P5 | : Oil pressure switch | T8 | : Main IT/TN selector |
| M2 | : Contactor | Q5 | : Water temperature switch | U8 | : NATO socket 12V |
| N2 | : G.F.I. and circuit breaker | R5 | : Water heater | V8 | : Diesel pressure switch |
| O2 | : 42V EEC socket | S5 | : Engine connector 24 poles | Z8 | : Remote control PCB |
| P2 | : G.F.I. resistor | T5 | : Electronic GFI relais | W8 | : Pressure turbo protection |
| Q2 | : T.E.P. engine protection | U5 | : Release coil, circuit breaker | X8 | : Water in fuel sender |
| R2 | : Solenoid control PCB | V5 | : Oil pressure indicator | Y8 | : EDC7-UC31 engine PCB |
| S2 | : Oil level transmitter | Z5 | : Water temperature indicator | A9 | : Low water level sender |
| T2 | : Engine stop push-button T.C.1 | W5 | : Battery voltmeter | B9 | : Interface card |
| U2 | : Engine start push-button T.C.1 | X5 | : Contactor, polarity change | C9 | : Limit switch |
| V2 | : 24V c.a. socket | Y5 | : Commutator/switch, series/parallel | D9 | : Starter timing card |
| Z2 | : Thermal magnetic circuit breaker | A6 | : Commutator/switch | E9 | : Liquid pouring level float |
| W2 | : S.C.R. protection unit | B6 | : Key switch, on/off | F9 | : Under voltage coil |
| X2 | : Remote control socket | C6 | : QEA control unit | G9 | : Low water level warning light |
| Y2 | : Remote control plug | D6 | : Connector, PAC | H9 | : Chopper driver PCB |
| A3 | : Insulation monitoring | E6 | : Frequency rpm regulator | I9 | : |
| B3 | : E.A.S. connector | F6 | : Arc-Force selector | L9 | : |
| C3 | : E.A.S. PCB | G6 | : Device starting motor | | |
| D3 | : Booster socket | H6 | : Fuel electro pump 12V c.c. | | |
| E3 | : Open circuit voltage switch | I6 | : Start Local/Remote selector | | |

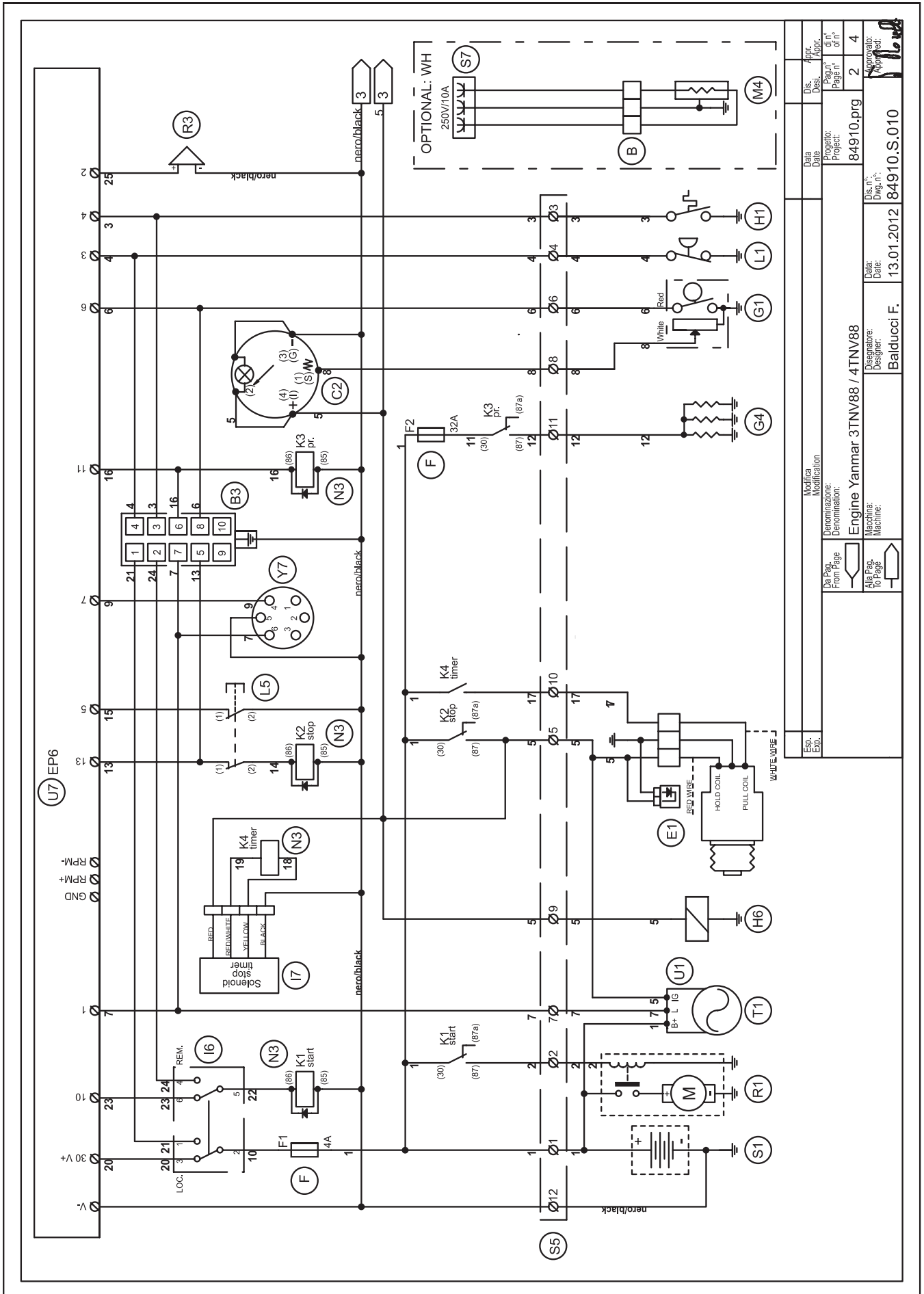

| Modifica | | Data | | Dis. n.° | | Appr. | |
|------------------------|--|-------------|--|-------------------|--|-------------|--|
| Modification | | Date | | Desig. n.° | | Appr. n.° | |
| Denominazione: | | 84910.prg | | 2 | | 4 | |
| Da Pag. From Page | | 84910.S.010 | | 2 | | 4 | |
| Alia Pag. to Page | | 84910.S.010 | | 2 | | 4 | |
| Disegnatore: Designer: | | Balducci F. | | Dis. n.° Dwg. n.° | | 84910.S.010 | |
| Macchina: Machine: | | Balducci F. | | Disegnato: Drawn: | | M.61 | |
| Data: Date: | | 13.01.2012 | | Disegnato: Drawn: | | M.61 | |

OPTIONAL

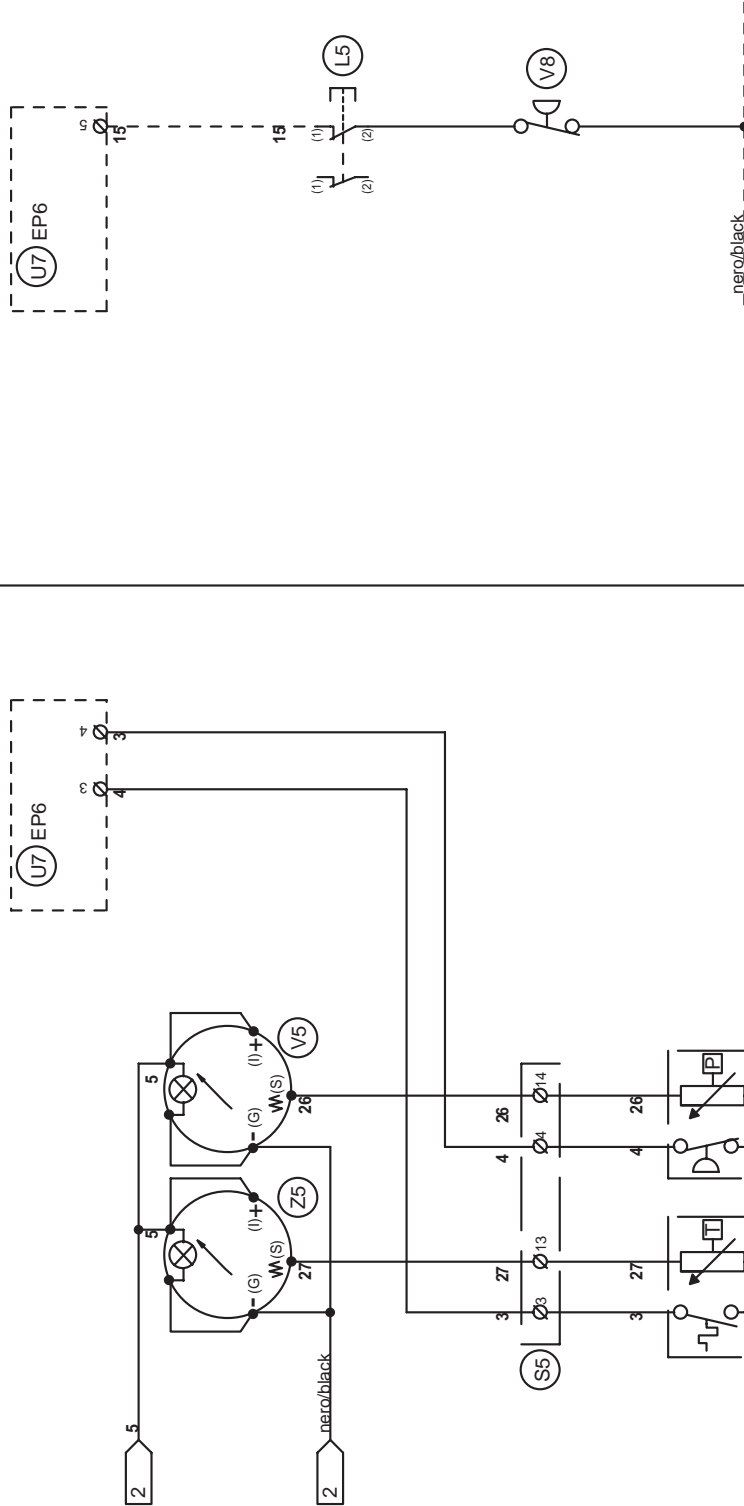

OPTIONAL: MG8

**OPTIONAL: KIT CARIC. CARBURANTE A 3 VIE (SOLO x GE 20-35)
OPTIONAL: 3 WAY FUEL CHARGE KIT (ONLY for GE 20-35)**

| | | | | | | | |
|-------------------|---|---|-------------|------------|----------------------|------|--|
| A | | Aggiunto OPTIONAL: Kit caricamento carburante a 3 vie | | 05.11.2012 | | B.F. | |
| Fig. Exp. | Modifica | Data | Dis. | Appr. | | | |
| | Modification | Date | Desi. | Appr. | | | |
| Da Pag. From Page | Denominazione: Denomination: | Progetto: di n° Project: of n° | | | | | |
| U7 | Gauges for water temp. & oil press. kit \ 3 way fuel charge kit | 84920.prg | | | | | |
| U7 | Macchina: Machine: | Dis. n°: Dwg. n°: | 3 | | 4 | | |
| | | Disegnato: Designer: | Balducci F. | | Approvato: Approver: | | |
| | | Data: Date: | 03.02.2012 | | 84920.S.012-A | | |

